

**MOUNTING HOLE POSITION  
AND CABINET SIZE REQUIREMENT**

ITEM SIZE(W\*H\*D): 300X140X430mm

## Installation steps:

- Step 1: Mark the mounting hole position mentioned above on bottom panel.
- Step 2: Hold ① back frame by hand, pull out ⑤ steel box 100mm, then you can see mounting holes on ① back frame, use screws to install preliminarily ① back frame to bottom panel.
- Step 3: Pull out ⑤ steel box and ⑥ supporting rod, unfold ⑧ ironing board to tiled condition
- Step 4: Unscrew ③ Locknut, turn ⑧ ironing board to 90°, then you can see mounting holes on ④ front frame, use screws to install ④ front frame to bottom panel.
- Step 5: Fold ⑧ ironing board, pull ⑥ supporting rod back, then pull ⑤ steel box back, finish installation

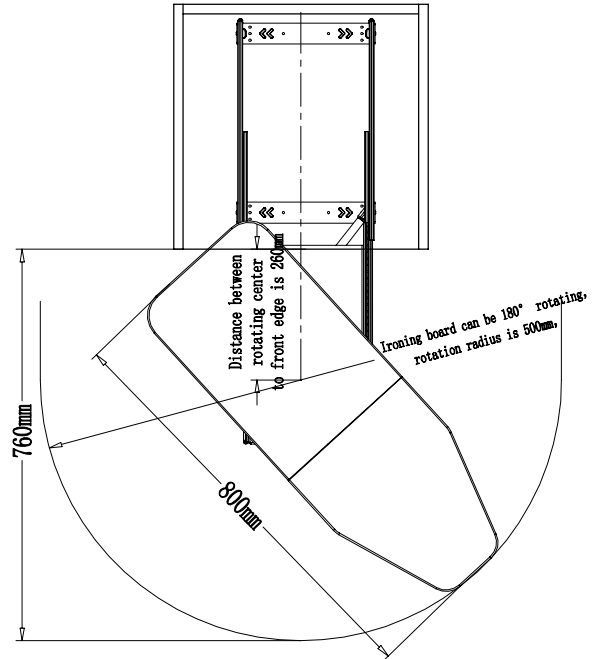
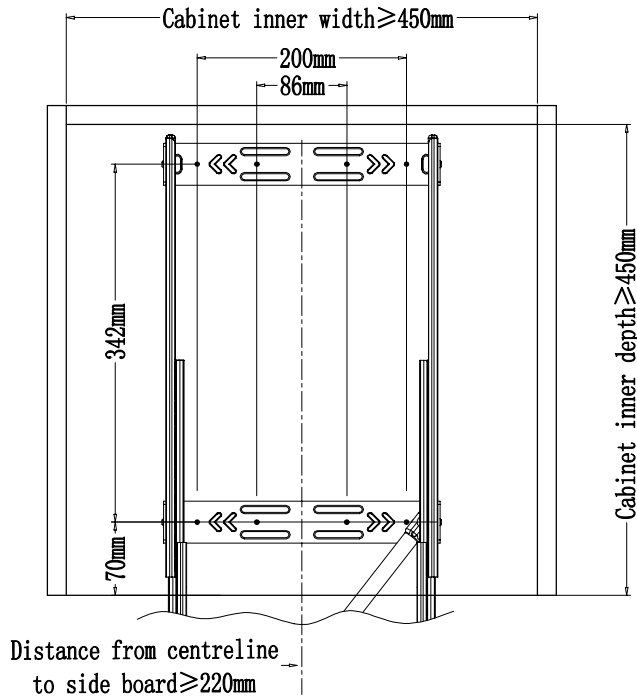
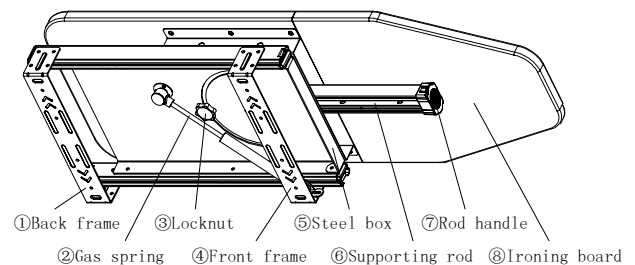

## Remarks:

1. When this item is pulled out or back in half way. it will trigger soft closing function.
2. When ③ Locknut is tight, ⑧ ironing board can not be roated.
3. When unfold ⑧ ironing board, ⑥ supporting rod must be full extended.