

TopLine XL



- de Montageanleitung**
2-bahniges, obenlaufendes Schiebetürensysteem für 3-türige Konstruktion
- cz Montážní návod**
Kování pro posuvné dveře s 2-dráhovým horním nosným profilem pro konstrukci se 3 křídly
- dk Monteringsvejledning**
Foroven kørende skydelågesystem med 2 baner til konstruktion med 3 låger
- es Instrucciones de montaje**
2-siAstema de puerta corredera de rodadura superior para tres puertas
- fi Asennusohje**
Kaksikiskoinen, ylhäällä kulkeva liukuovijärjestelmä kolmioviseen rakenteeseen
- fr Instructions de montage**
Système de porte coulissante à 2 voies, coulissant par le haut, pour un montage à 3 portes
- en Installation instructions**
2-track, top running sliding door system for 3-door construction
- it Istruzioni di montaggio**
Sistema di ante scorrevoli con portata sul binario superiore per costruzioni di armadi a 3 ante
- nl Montagehandleiding**
2 baans, bovenlopend schuifdeurbeslag voor 3-deurs constructie
- pl Instrukcja montażu**
2-torowy system do drzwi przesuwanych z górnym mechanizmem jezdny, do konstrukcji 3-drzwiowej
- ru Инструкция по монтажу**
двухдорожечная система для раздвижных дверей с верхним ходовым профилем для 3 дверей
- se Monteringsanvisning**
2-spårigt, topplöpande skjutdörrsystem för konstruktion med 3 dörrar
- tr Montaj kılavuzu**
3-Kapaklı dolap konstrüksiyonları için 2-Kanalı, üstte çalışan sürgü kapak sistemi
- ko 설치 설명서**
3문용 2트랙 상부 러미 라인 시스템
- ja 金具取付けマニュアル**
上吊り式引き戸システム、2トラックシステム、3枚扉用
- zh 安装说明**
双轨道，用于三门柜体的顶部滑动移门系统

Technik für Möbel

Hettich

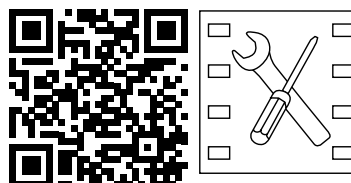

<http://www.hettich.com/short/1110e6>

Montageanimation
Montážní animace
Installation Animation
Video de montaje
Montageanimation
Vidéo d'installation
Installation animation
Animazione del montaggio
Montagefilm
Film montażowy
Montageanimation
Montaj animasyonu
取付説明動画
설치 애니메이션
安装视频

		2 - 5
		6 - 9
		10 - 33
		34 - 36
		37 - 38

de	Produkt Sets	Informationen	Planung	Montage	Verstellung	Demontage
cz	Sady výrobků	Informace	Navrhování	Montáž	Seřizování	Demontáž
dk	Produkt Sæt	Informationer	Planlægning	Montering	Justering	Afmontering
es	Sets de producto	Información	Planificación	Montaje	Ajuste	Desmontaje
fi	Tuote setti	Tietoja	Suunnittelu	Asennus	Säätää	Purkaminen
fr	Produit kits	Informations	Planification	Montage	Réglage	Démontage
en	Product sets	Information	Planning	Installation	Adjustment	Removal
it	Kit prodotto	Informazioni	Progettazione	Montaggio	Regolazione	Smontaggio
nl	Product sets	Informatie	Planning	Montage	Verstelling	Demontage
pl	Zestawy produktów	Informacje	Planowanie	Montaż	Regulacja	Demontaż
ru	Комплект	Информация	Проектирование	Монтаж	Регулировка	Демонтаж
tr	· r · n setleri	Bilgiler	Planlama	Montaj	Ayarlama	Demontaj
ko	取外し	インフォメーション	プランニング	取り付け	調整	取外し
ja	제0 세트	정보	계0	설치치	조0	해체
zh	产品套装	信息	规划设计	安装	调节	拆卸

de WICHTIG !
VOR GEBRAUCH SORGFÄLTIG LESEN
AUFBEWAHREN FÜR SPÄTERES NACHSCHLAGEN

cz DŮLEŽITÉ!
PŘED POUŽITÍM POZORNĚ PŘEČTĚTE
ULOŽTE PRO POZDĚJŠÍ POTŘEBU

dk VIGTIG!
LÆSES OMHYGGELIGT FØR BRUG
OPBEVARES TIL SENERE BRUG

es ¡IMPORTANTE!
LEER DETENIDAMENTE ANTES DE USAR
GUARDAR EN LUGAR SEGURO PARA FUTURAS CONSULTAS

fi TÄRKEÄ!
LUE HUOLELLISESTI ENNEN KÄYTTÖÄ
SÄILYTETTÄVÄ TURVAKLLISESSA PAIKASSA MYÖHEMPÄÄ
TARVETTA VARTEN

fr IMPORTANT !
LIRE ATTENTIVEMENT AVANT UTILISATION
CONSERVER EN LIEU SÛR POUR CONSULTATION ULTÉRIEURE

en IMPORTANT!
READ CAREFULLY BEFORE USE
KEEP IN A SAFE PLACE FOR FUTURE REFERENCE

it IMPORTANTE!
LEGGERE ATTENTAMENTE PRIMA DELL'USO
CONSERVARE PER CONSULTARE IN SEGUITO

nl BELANGRIJK!
VOOR GEBRUIK ZORGVULDIG LEZEN
BEWAREN ALS NASLAGWERK

pl WAŻNE!
PRZED UŻYCIEM NALEŻY DOKŁADNIE PRZECZYTAĆ
ZACHOWAĆ DO WYKORZYSTANIA W PRZYSZŁOŚCI

ru ВАЖНО!
ВНИМАТЕЛЬНО ИЗУЧИТЕ ИНФОРМАЦИЮ ПЕРЕД
ИСПОЛЬЗОВАНИЕМ
ХРАНИТЕ В БЕЗОПАСНОМ МЕСТЕ ДЛЯ БУДУЩЕГО
ИСПОЛЬЗОВАНИЯ

tr ÖNEMLİ!
KULLANMADAN ÖNCE DİKKATLİCE OKUYUNUZ.
DAHA SONRAKI KULLANIM İÇİN SAKLAYINIZ.

ko 중요성!
사용전 주의0게 0어주세요
안전한 장소에 보관해주세요

ja 重要事項
ご使用前に必ずご確認ください
本書は必要なときにすぐに取り出せるよう、大切に保管し
てください。

zh 注意!
在使用之前请仔细阅读说明书
保存好说明书以备后用

de Bestimmungsgemäße Verwendung

Der Möbelbeschlag TopLine XL wird für obenlaufende Schiebe-
türsysteme verwendet.

Er ist für die Verwendung in Möbeln nach EN 14749 und den
Einsatz in geschützten, trockenen Innenräumen vorgesehen.

Eine andere als die unter „Bestimmungsgemäße Verwendung“
festgelegte Verwendung gilt als nicht bestimmungsgemäß.

Der Beschlag ist getestet nach EN 15706, Level 3.

Es wird empfohlen, den Schrank gegen Kippen zu sichern.

cz Použití v souladu s určením

Nábytkové kování TopLine XL se používá pro systémy posuvných
dveří s horním nosným profilem.

Je určeno do nábytku podle EN 14749 a pro použití v chráněných
a suchých interiérech.

Jiné použití, než které je definované pod bodem „Použití v souladu
s určením“, se považuje za nesprávné.

Kování je testováno podle EN 15706, úroveň 3.

Doporučuje se zajistit skříň proti překlopení.

dk Tilsigtet brug

Møbelbeslaget TopLine XL anvendes til skydelågesystemer, der kører foroven.

Det er beregnet til anvendelse i møbler i overensstemmelse med EN 14749 og til brug i beskyttede, tørre indendørs lokaler. Anden brug end den, der er fastlagt under „Tilsigtet brug“, betragtes som utilsigtet brug.

Beslaget er testet iht. EN 15706, level 3.

Det anbefales at sikre skabet mod at vælte.

es Utilización conforme al uso previsto

El herraje de mueble TopLine XL se utiliza para sistemas de puerta corredera con deslizamiento superior.

Está previsto para el uso en muebles según EN 14749 y su aplicación en estancias protegidas y secas.

Cualquier otra utilización que difiera de la „Utilización conforme al uso previsto“ se considera no conforme a lo previsto.

El herraje ha sido verificado conforme a EN 15706, nivel 3.

Se recomienda asegurar el armario para evitar que pueda volcar.

fi Käyttötarkoitus

TopLine XL -huonekaluhelaa käytetään ylhäällä kulkevilla liukuovijärjestelmissä.

Se on tarkoitettu käytettäväksi huonekaluissa EN 14749 -standardin mukaisesti ja sitä voidaan käyttää suojatuissa, kuivissa sisätiloissa.

Kaikenlainen muu kuin „käyttötarkoituksen mukainen“ käyttö ei ole käyttötarkoituksen mukaista käyttöä.

Hela on testattu EN 15706 -standardin, taso 3, mukaisesti.

Kaappi kannattaa varmistaa kaatumista vastaan.

fr Utilisation conforme à la destination prévue

La ferrure de meuble TopLine XL est utilisée pour les systèmes de portes coulissant par le haut.

Elle est prévue pour une utilisation dans des meubles conformément à la norme EN 14749 et, à l'intérieur, dans des pièces non humides et protégées.

Toute utilisation autre que celle indiquée dans l'« utilisation conforme à la destination prévue » est considérée non-conforme.

La ferrure est testée selon la norme EN15706, niveau 3.

Il est conseillé de sécuriser l'armoire pour éviter qu'elle ne bascule.

en Intended Use

The TopLine XL furniture fitting is used for top running sliding door systems.

It is intended for application in furniture to EN14749 and use in dry indoor environments where it is protected from the elements.

Any use other than that defined under „Intended Use“ will be deemed to be non-intended use.

The fitting is tested to EN 15706, Level 3.

It is recommended to prevent the cabinet from toppling over.

it Uso conforme alla destinazione

Il dispositivo per mobili TopLine XL viene utilizzato come sistema per ante scorrevoli su binario superiore.

Il suo uso è previsto in mobili conformi alla norma EN 14749 e in ambienti interni protetti e asciutti.

Ogni altro utilizzo diverso da quanto indicato al punto "Uso conforme alla destinazione" viene considerato non conforme.

Il sistema è testato secondo la EN 15706, Level 3.

Si consiglia di fissare il mobile per evitare che si ribalti.

nl Doelmatig gebruik

Meubelbeslag TopLine XL wordt voor bovenaan lopende schuifdeur systemen gebruikt.

Het is gemaakt voor gebruik in meubels volgens EN 14749 en toepassing in beschutte, droge binnenruimtes.

Elk ander gebruik dan vastgelegd onder ‚Doelmatig gebruik‘ geldt als zijnde niet volgens de voorschriften.

Het beslag werd getest volgens EN 15706, level 3.

Wij adviseren de kast te beveiligen tegen kantelen.

pl Zastosowanie zgodne z przeznaczeniem

Okucie meblowe TopLine XL stosowane jest w systemach do drzwi przesuwanych z górnym mechanizmem jezdnym. Przeznaczone jest do zastosowania w meblach zgodnie z EN 14749 oraz do zastosowania w osłoniętych, suchych pomieszczeniach wewnętrznych.

Zastosowanie inne niż określone jako „Zastosowanie zgodne z przeznaczeniem“ jest niezgodne z przeznaczeniem.

Okucie zostało przetestowane zgodnie z EN 15706, poziom 3.

Zaleca się zabezpieczyć szafy przed przewróceniem się.

ru Использование по назначению

Фурнитура TopLine XL предназначена для использования в конструкциях с раздвижными дверями с верхним ходовым элементом.

Она предусмотрена для использования в мебели по стандарту EN 14749 и для применения в защищенных, сухих внутренних помещениях.

Иное применение, кроме указанного в разделе „Использование по назначению“, считается использованием не по назначению.

Фурнитура испытана по стандарту EN 15706, уровень 3.

Рекомендуется принять меры против опрокидывания шкафа.

tr Amacına uygun kullanım

Mobilya aksami TopLine XL, üstten hareketli sürmeli kapak sistemleri için kullanılır.

EN 14749 standardına uygun, kuru ve korunaklı iç mekan mobilyalarında kullanım için öngörülmüştür.

„Amacına uygun kullanım“ başlığı altında öngörülenin dışındaki bir kullanım, amacına aykırı olarak nitelendirilir.

Aksam, EN 15706, Seviye 3 uyarınca test edilmiştir.

Dolabın, devrilmeye karşı emniyete alınması önerilir.

ko 사용용도

TopLine XL은 상부 러닝방식의 슬라이딩 도어 시스템입니다.

EN14749에 따라 인증된 가구용 링으로서 손상을

방지하기 위해 건조한 실내에서 사용해야 합니다.

제시된 목적 이외의 용도에는 사용할 수 없습니다.

이 링은 EN 15706, Level 3에 따라 테스트 완료 하였습니다.

설치시 수직을 고려하지 않도록 유의하시기 바랍니다.

ja 用途

トップラインXLは吊り戸タイプの引き戸金物です。

上部レールで支える吊り戸タイプです。

通常の屋内（異常な高湿度及び温度ではない環境）に設置される家具以外での使用には

適しません。

この金具はヨーロッパ品質基準EN 15706のレベル3の試験をパスしています。

家具本体は転倒せぬよう必ず建築躯体に固定してください。

zh 用途

TopLine XL 家具配件应用于顶部滑动的移门系统。专为符合 EN 14947 标准定义的干燥室内环境下使用的家具而设计。

在非上述标准定义的环境中使用此配件将被视为“非正常使用”。

配件符合 EN 15706 三级标准。

为防止柜体倾覆，建议从柜体顶部将其固定至墙面

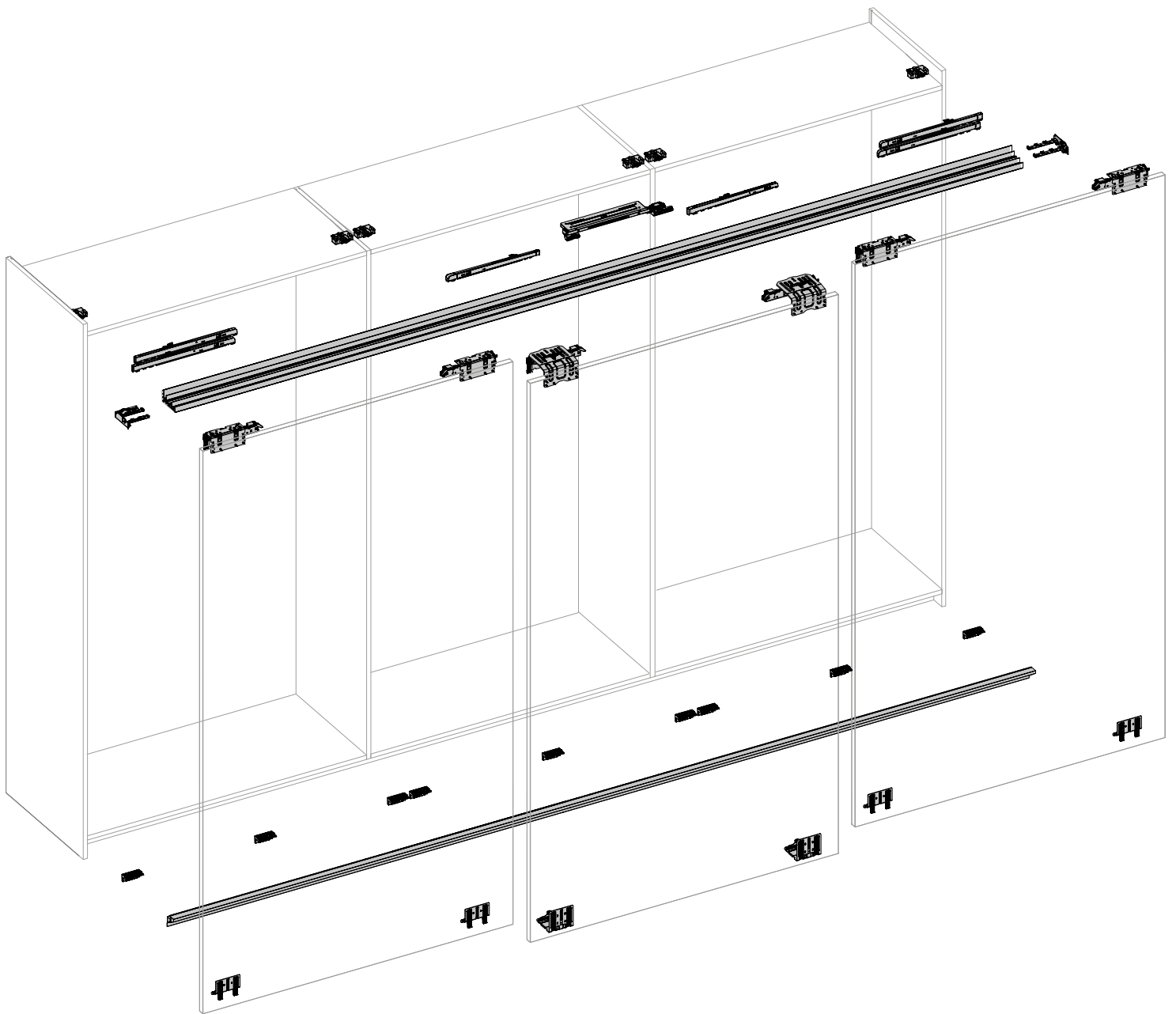

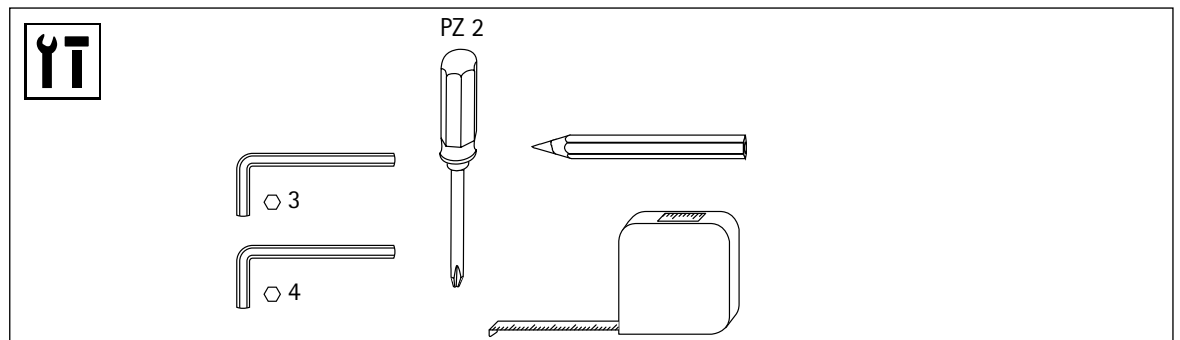
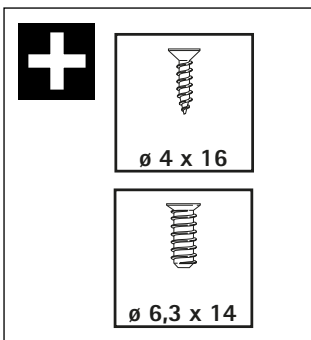
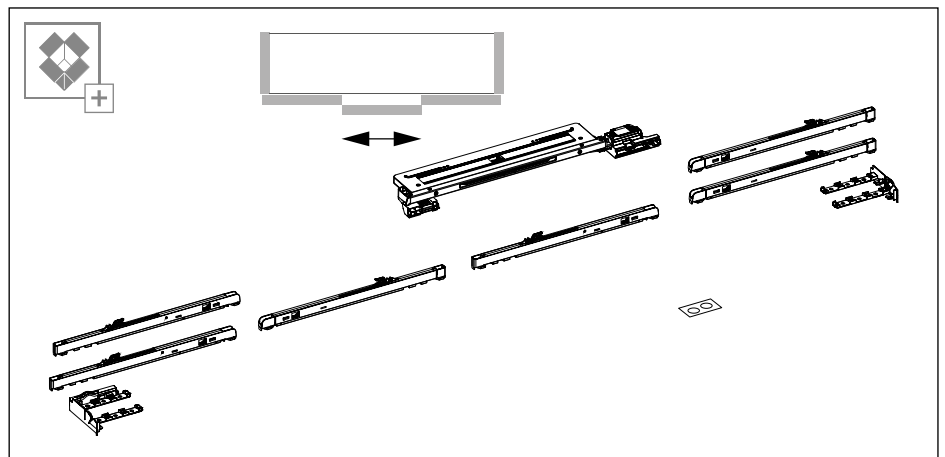
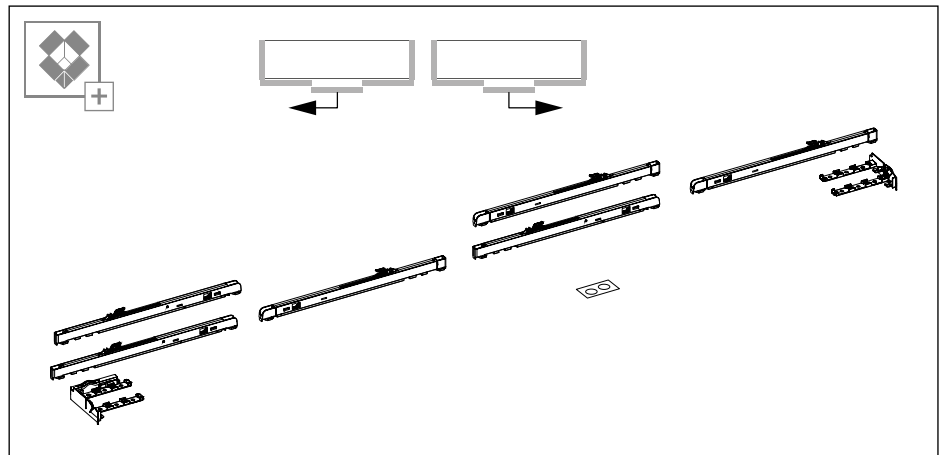
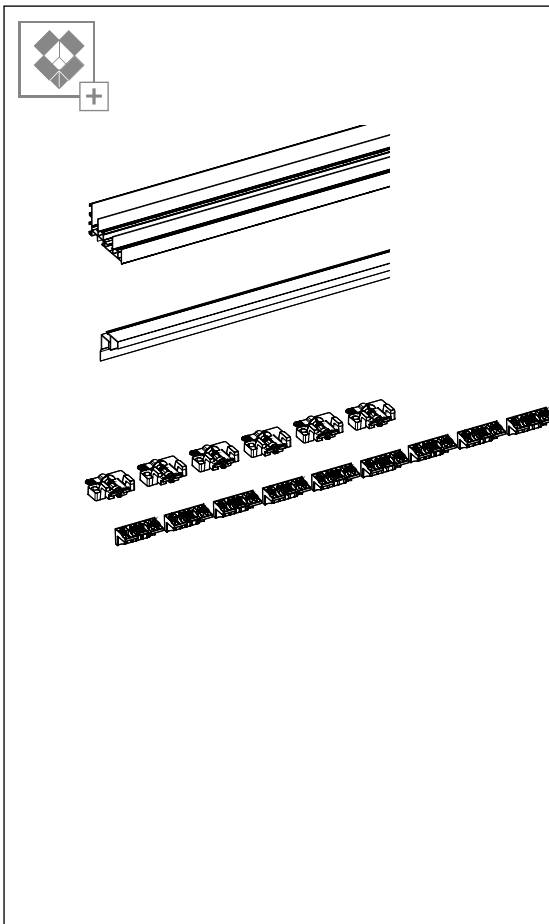
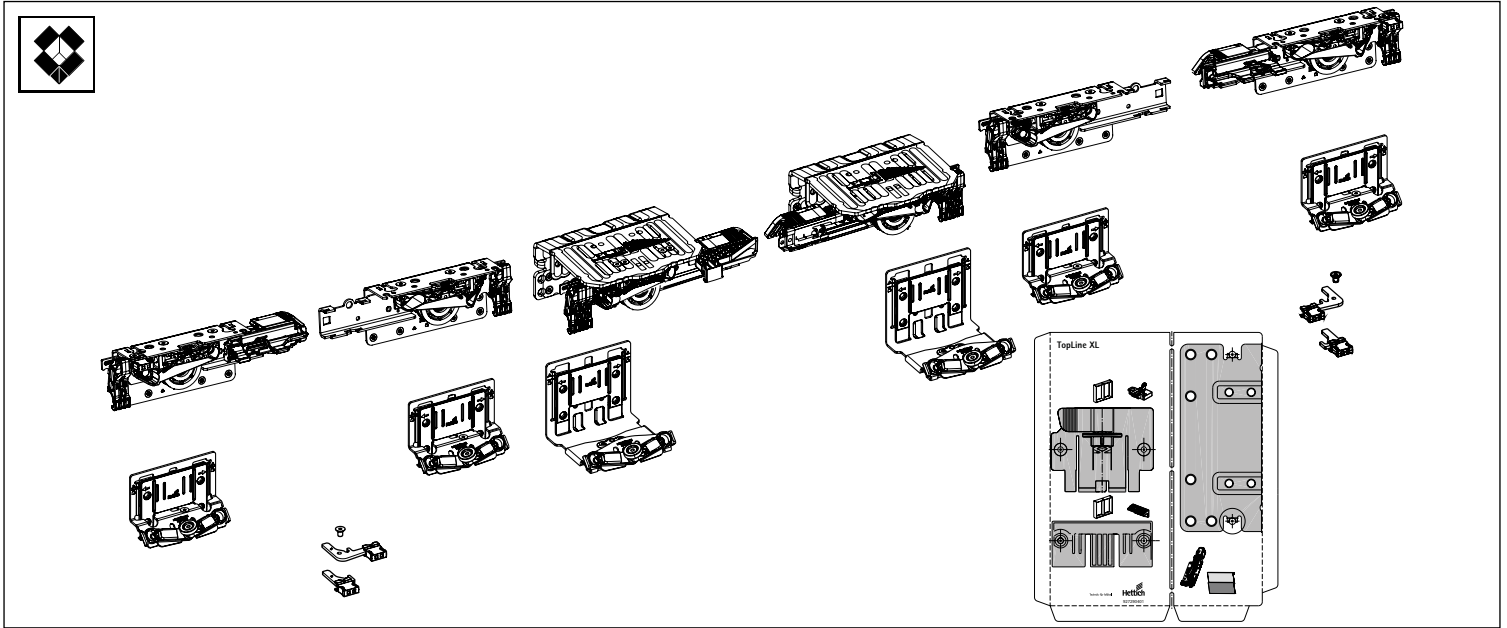

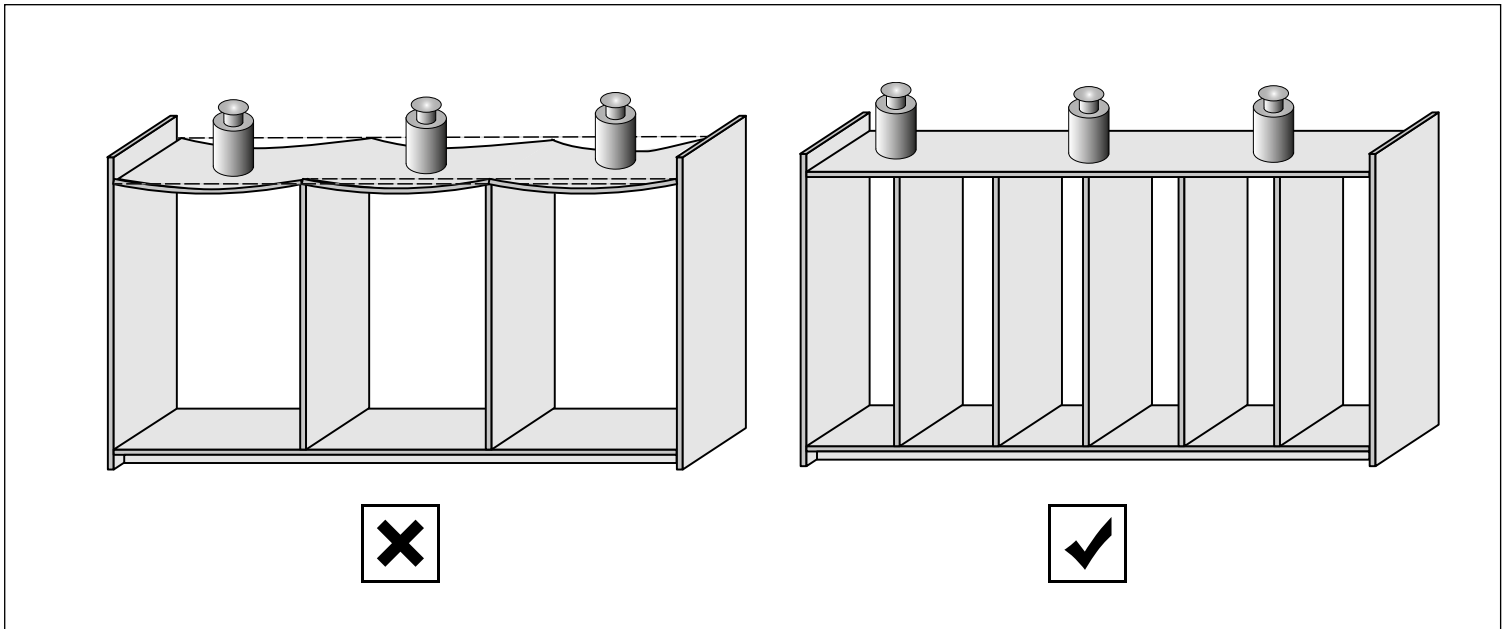
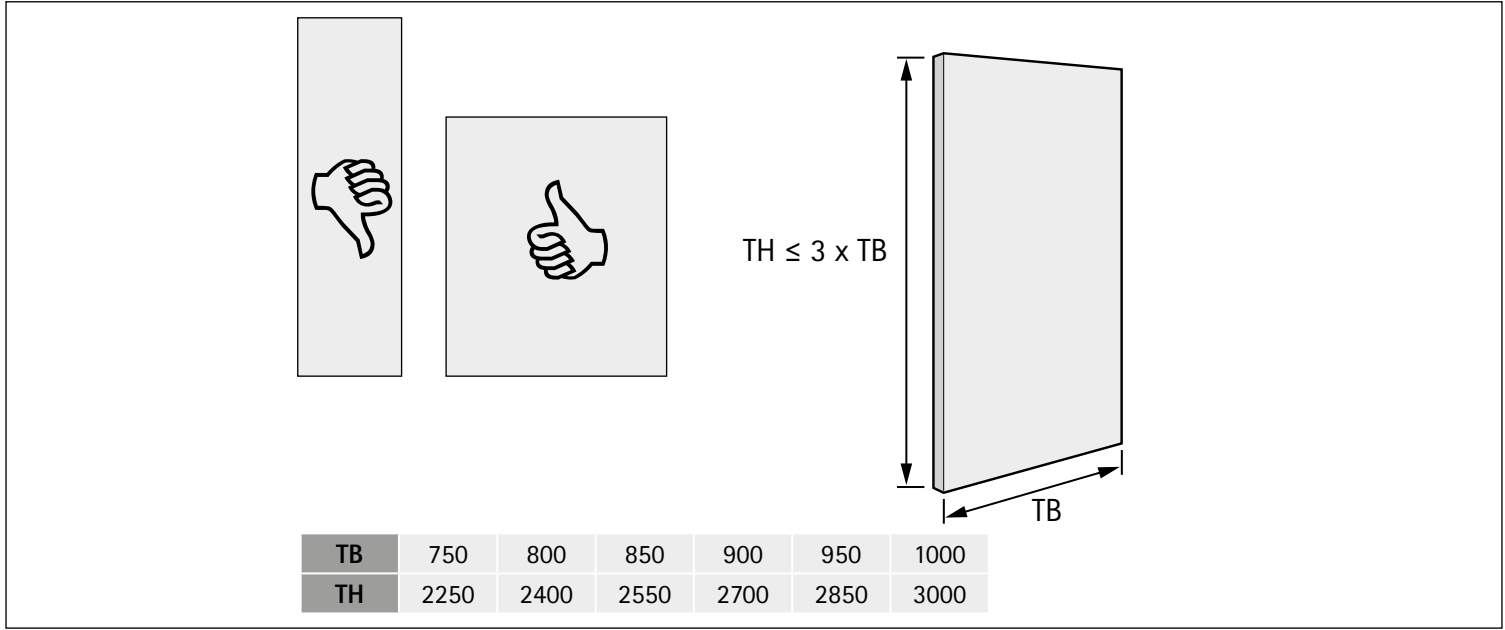
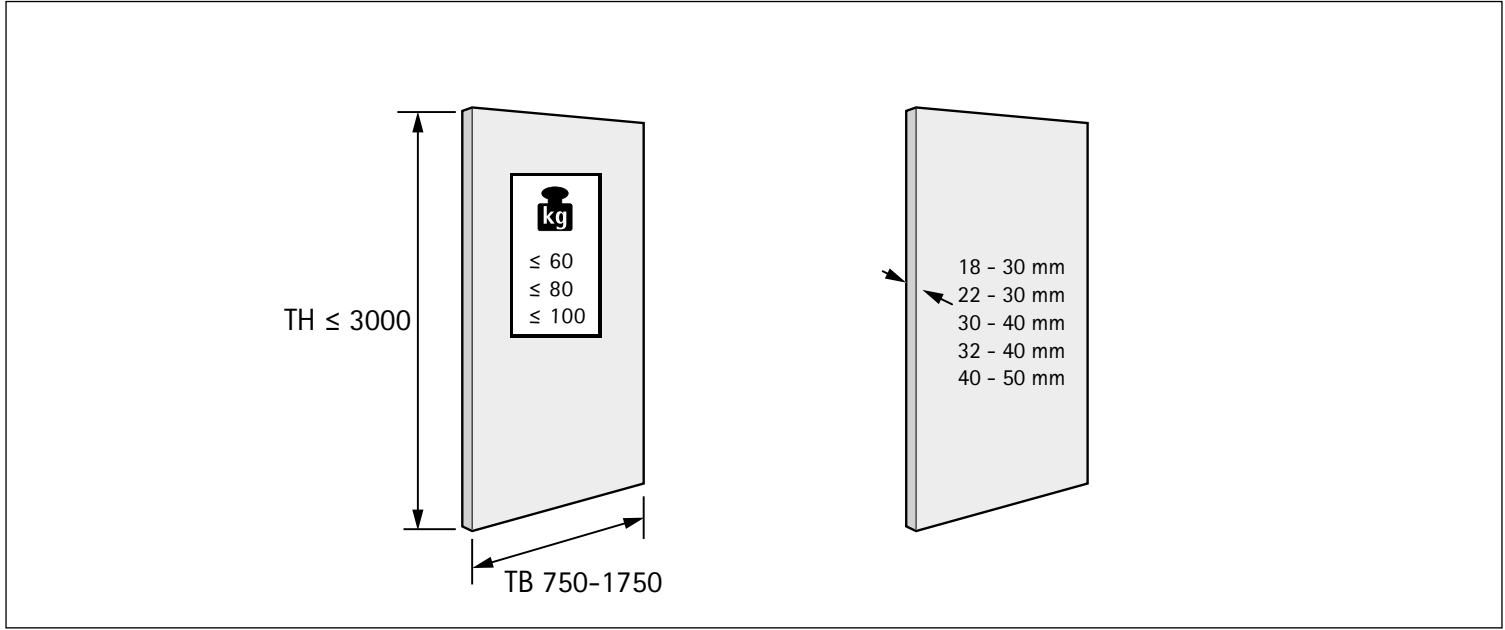

A

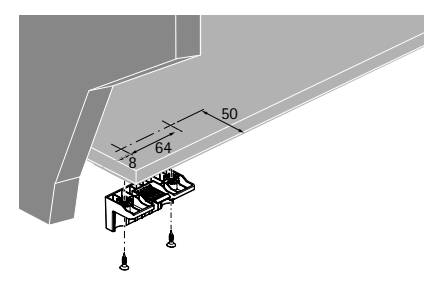
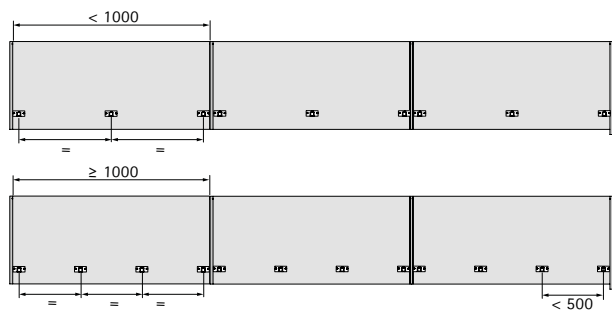
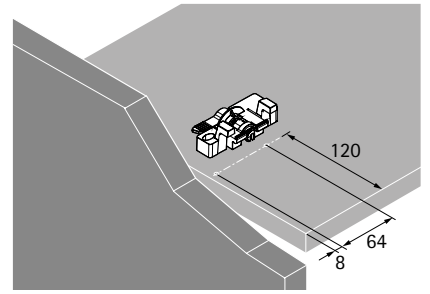
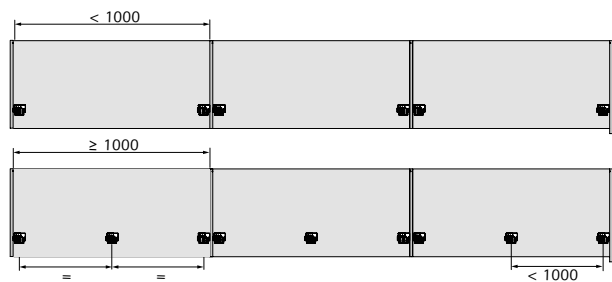
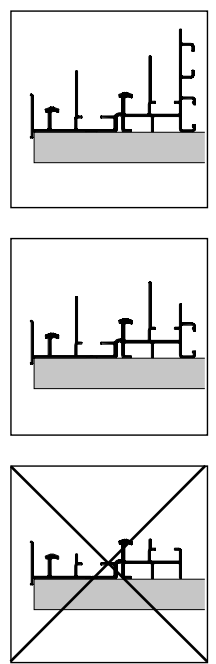
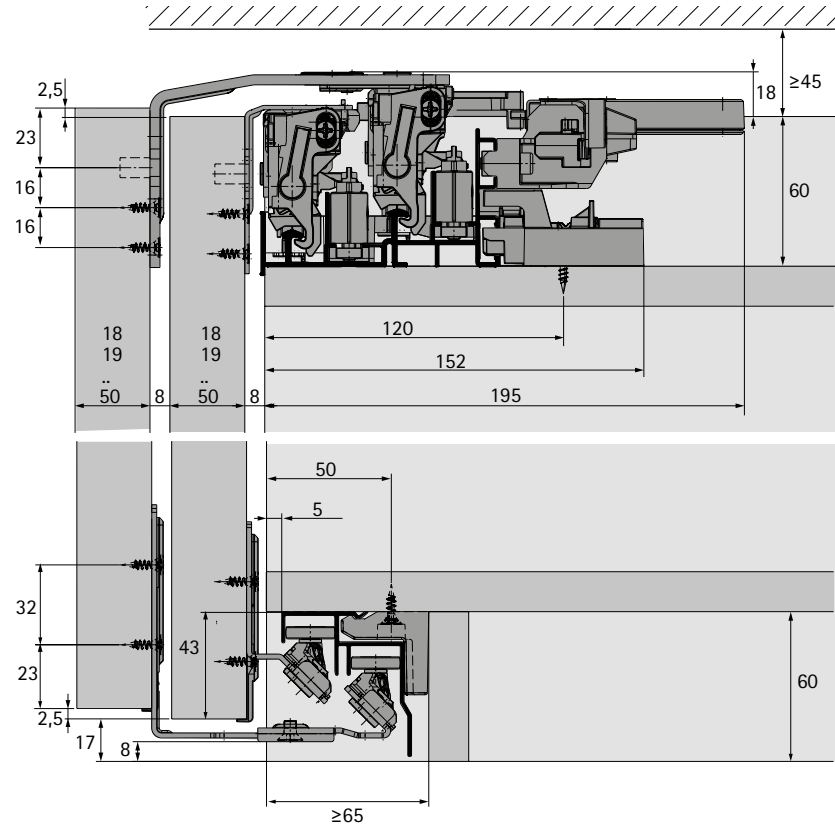

B

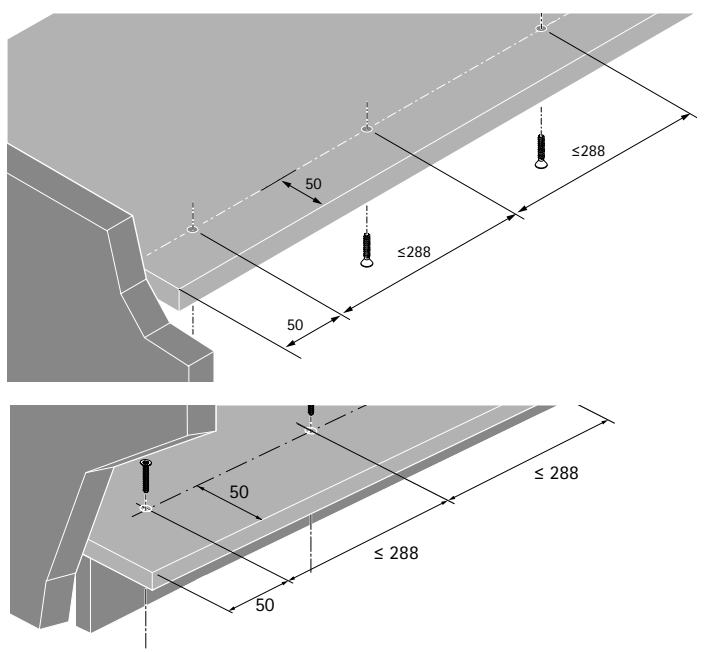
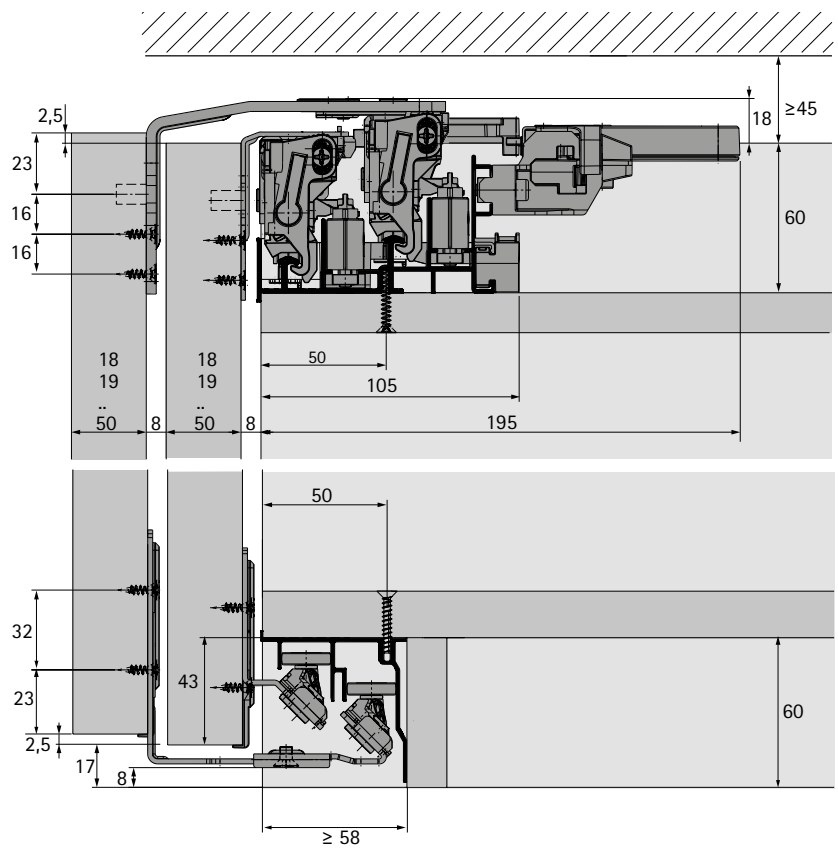

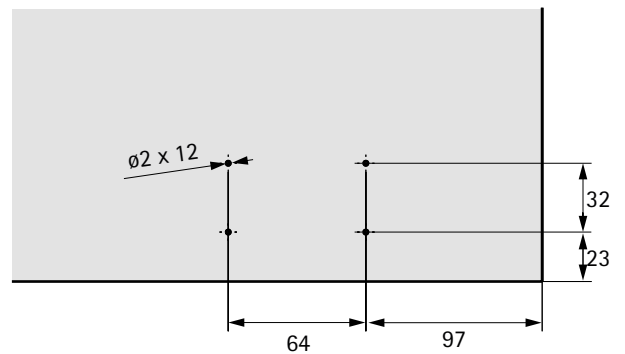
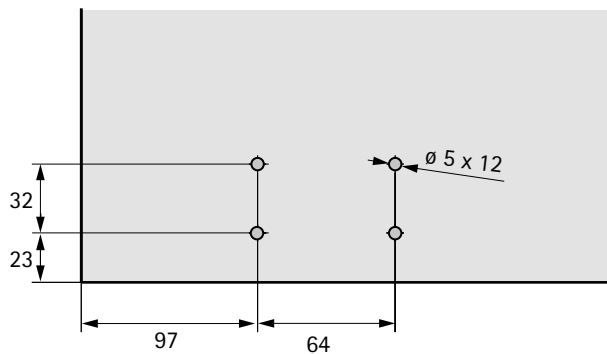
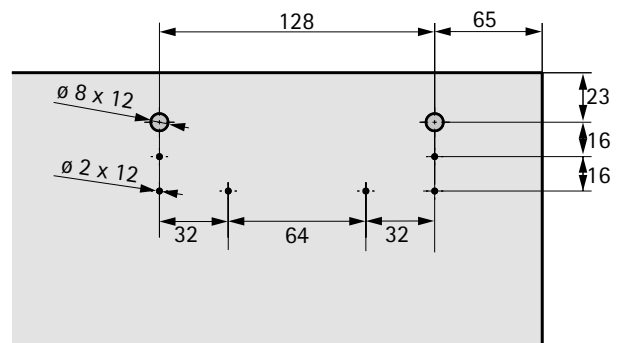
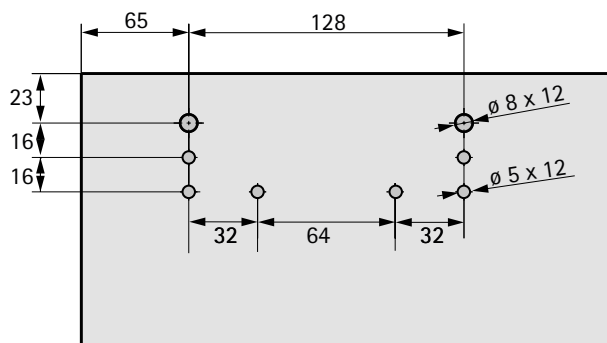
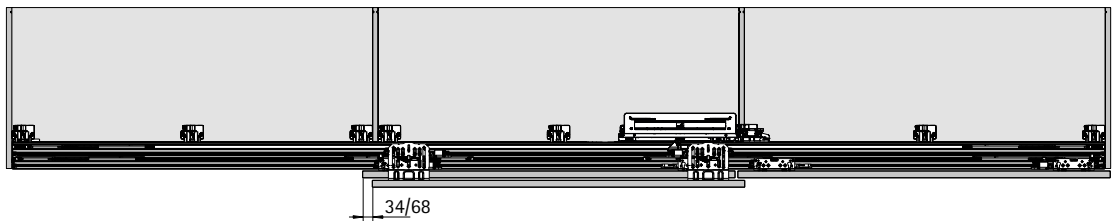
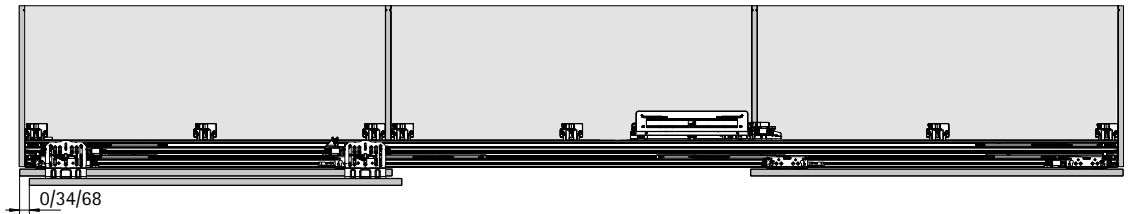
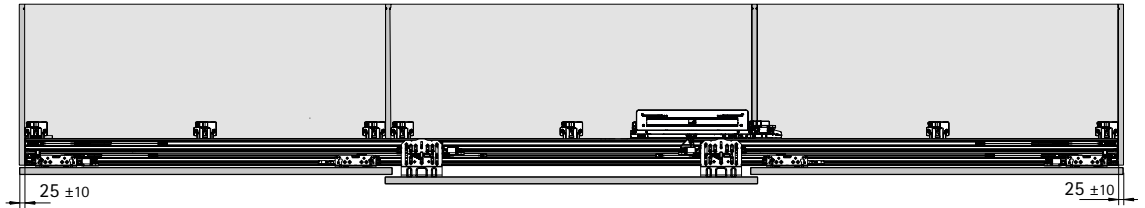

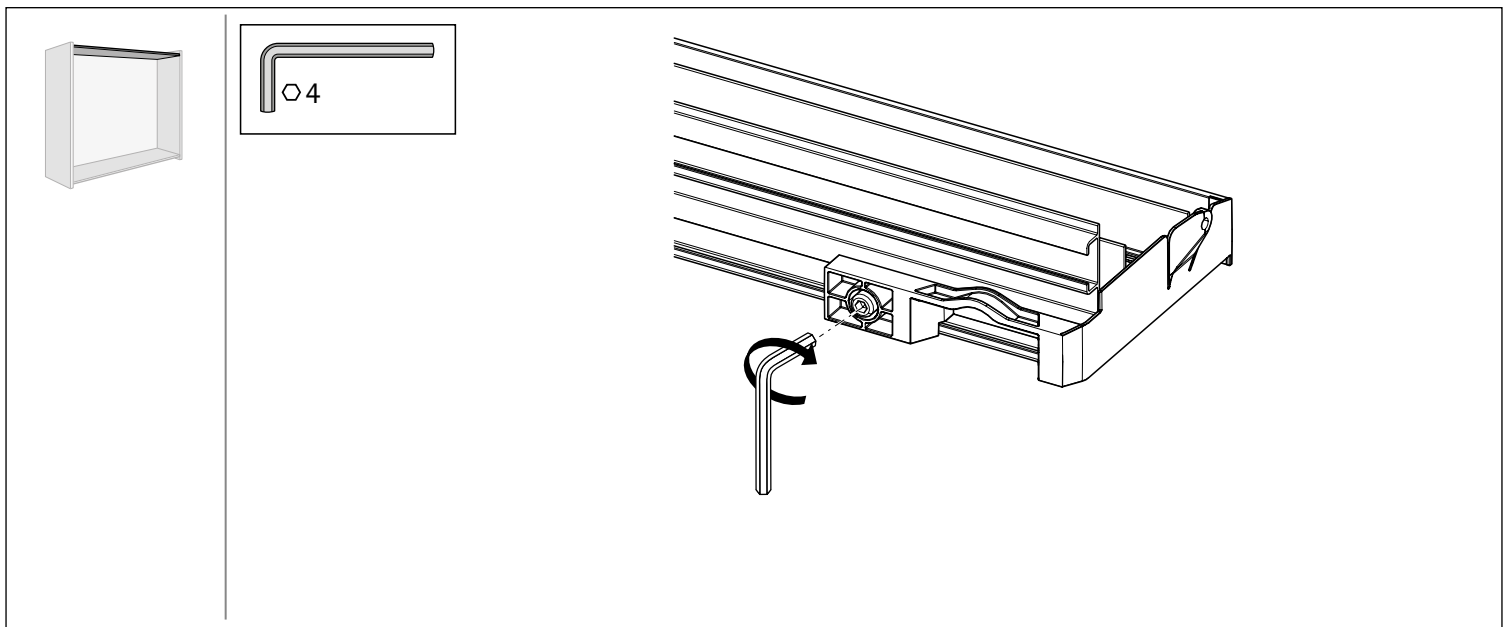
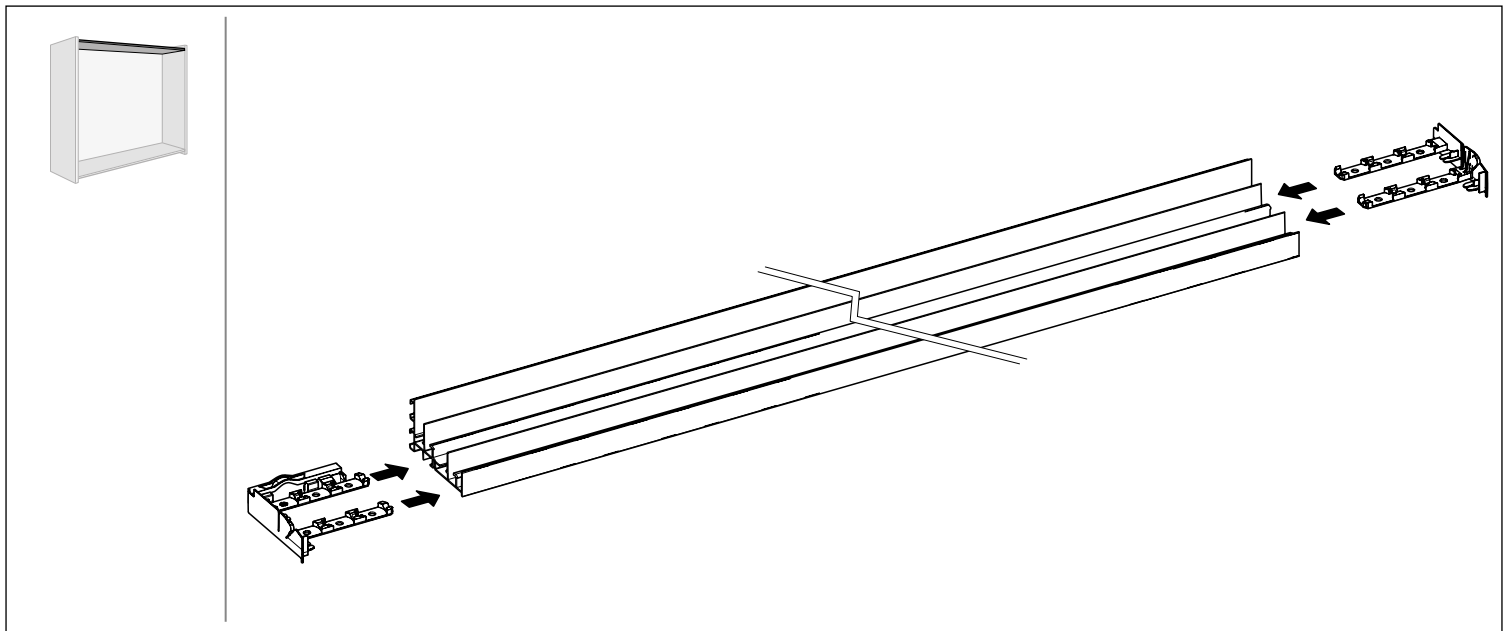
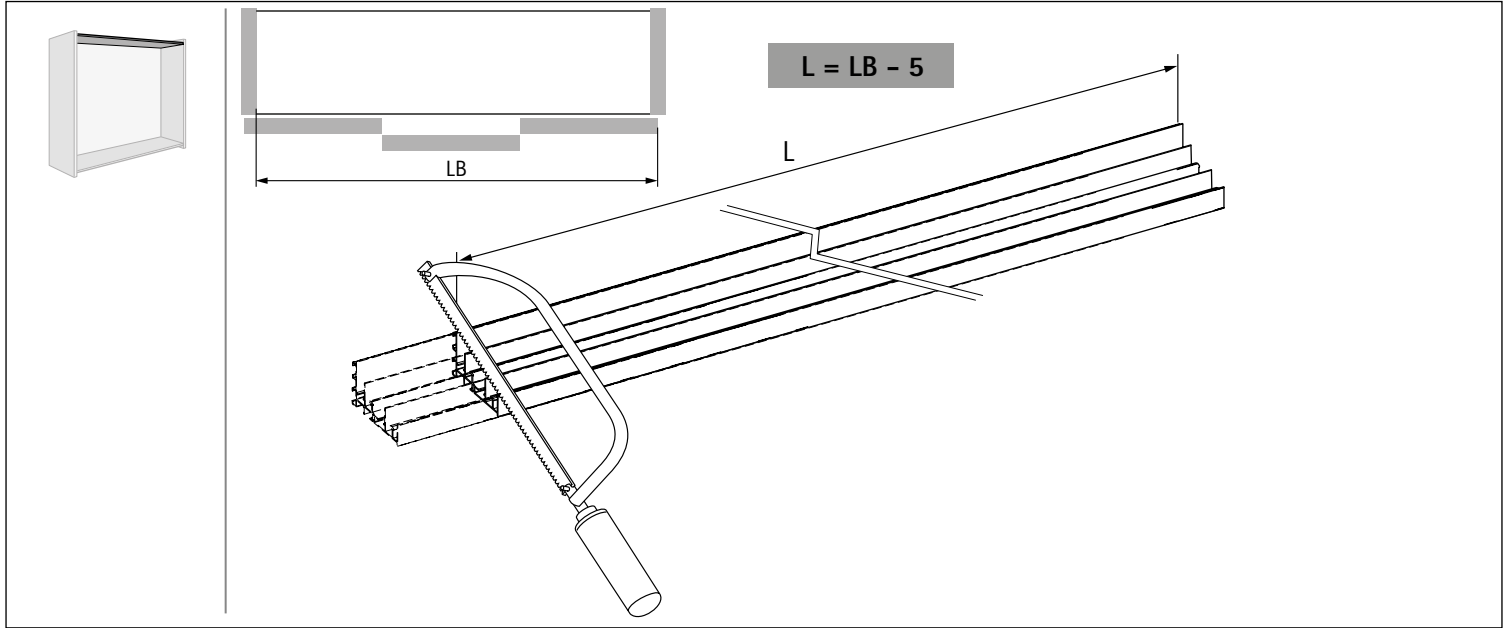

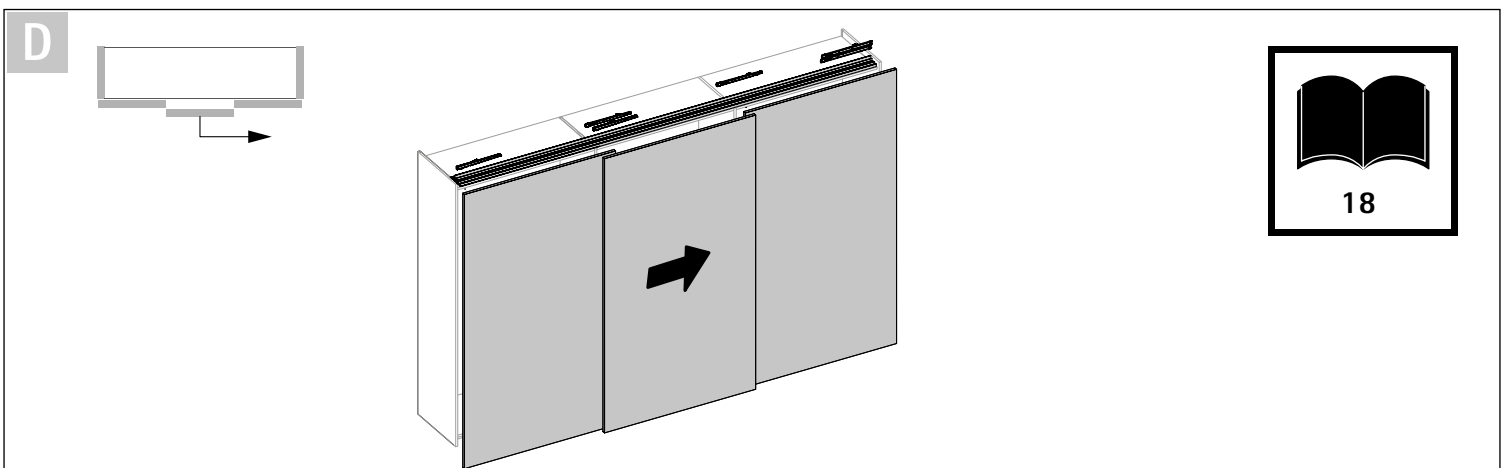
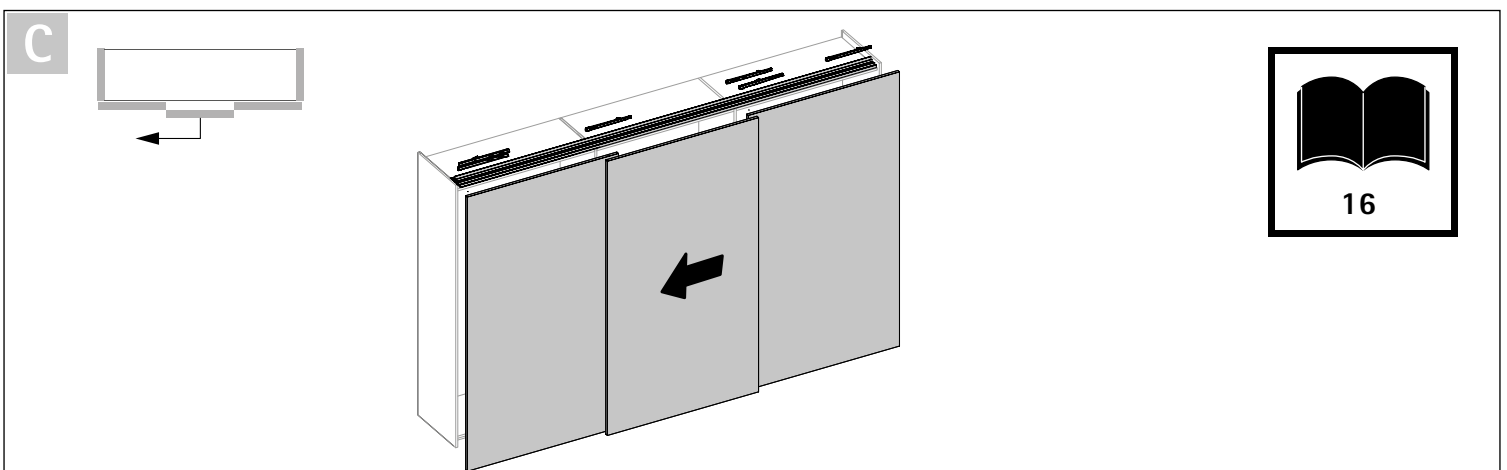
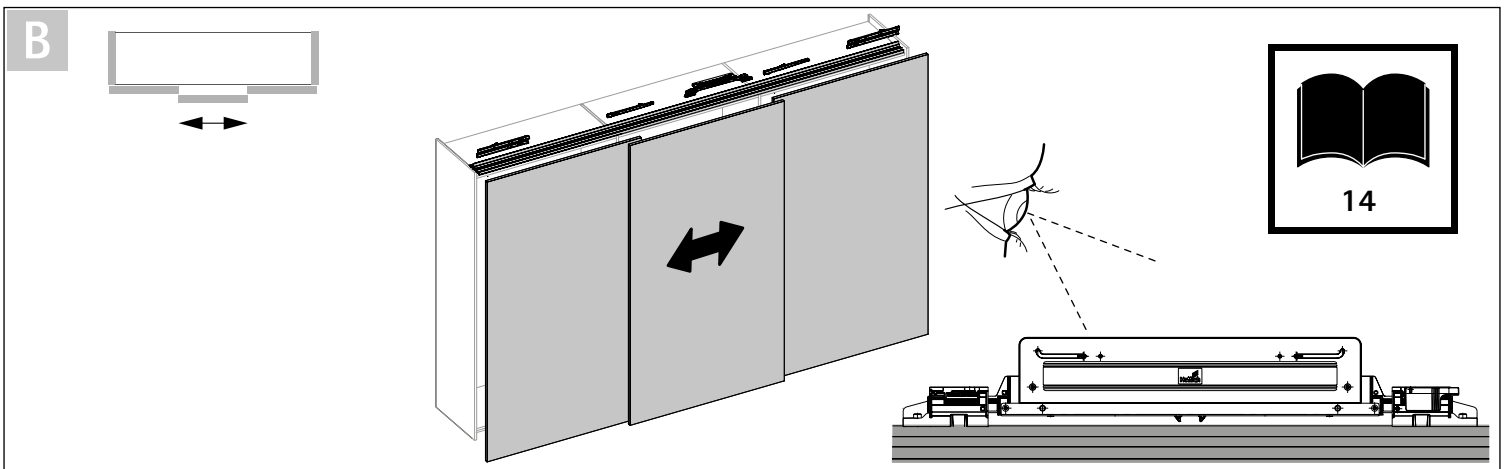
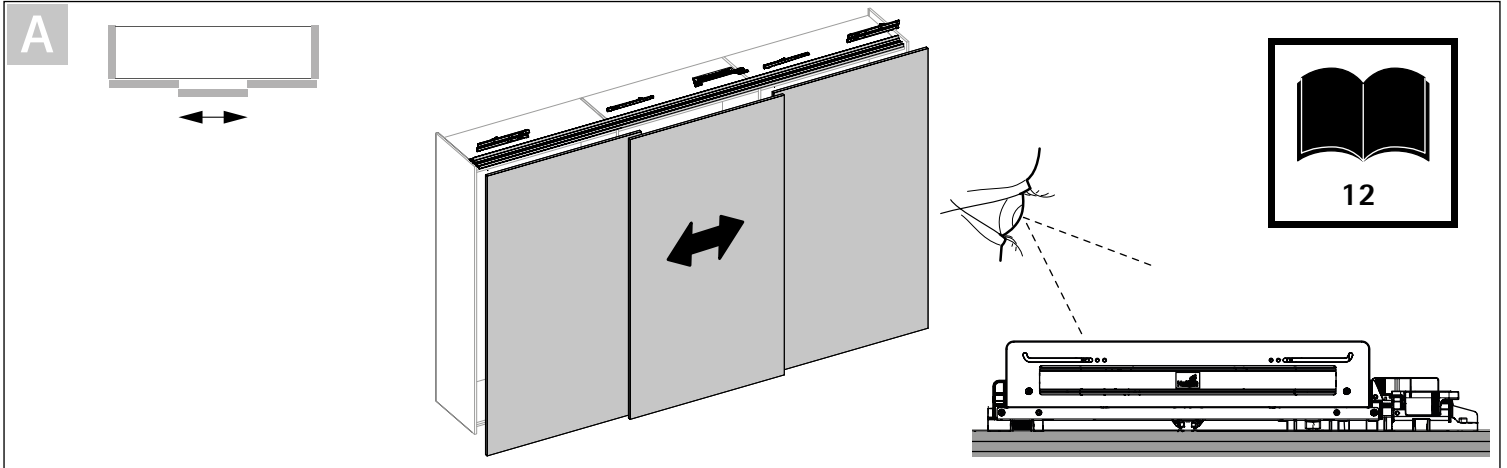



A

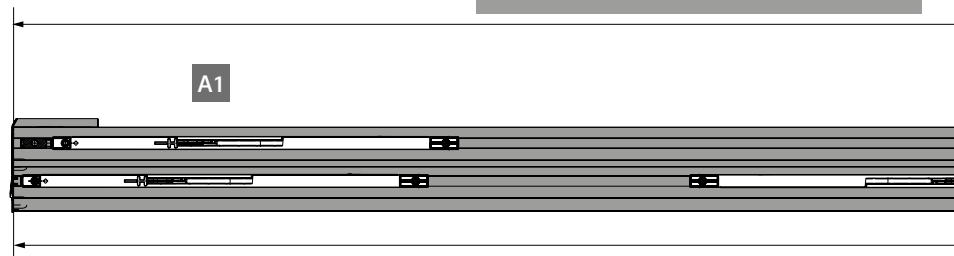
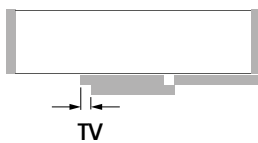
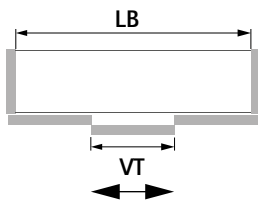
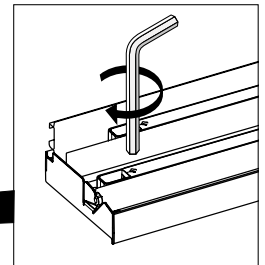
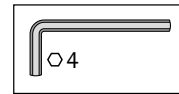
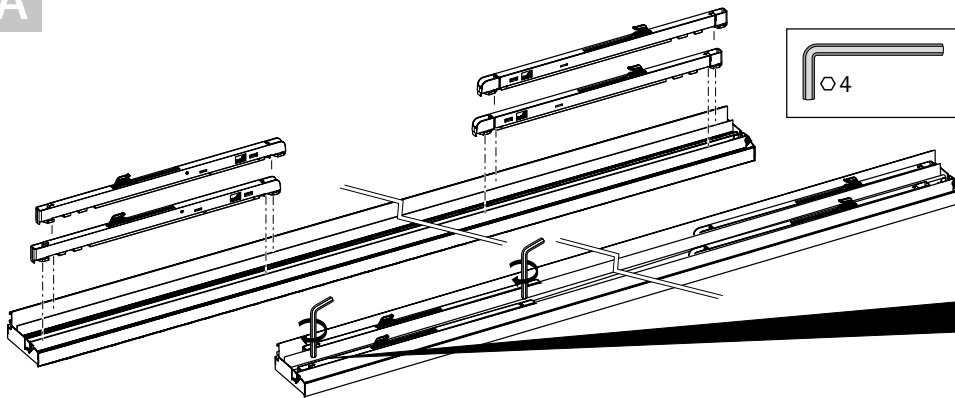

$$f = \frac{\text{LB} + \text{VT}}{2} - 417$$

$$g = \frac{\text{LB} - \text{VT}}{2} - \text{TV} + 392$$

	<p>0</p>	<p>A1</p>	<p>A2</p>
<p>34</p>	<p>34</p>	<p>A1</p>	<p>A2</p>
<p>68</p>	<p>68</p>	<p>A1</p>	<p>A2</p>

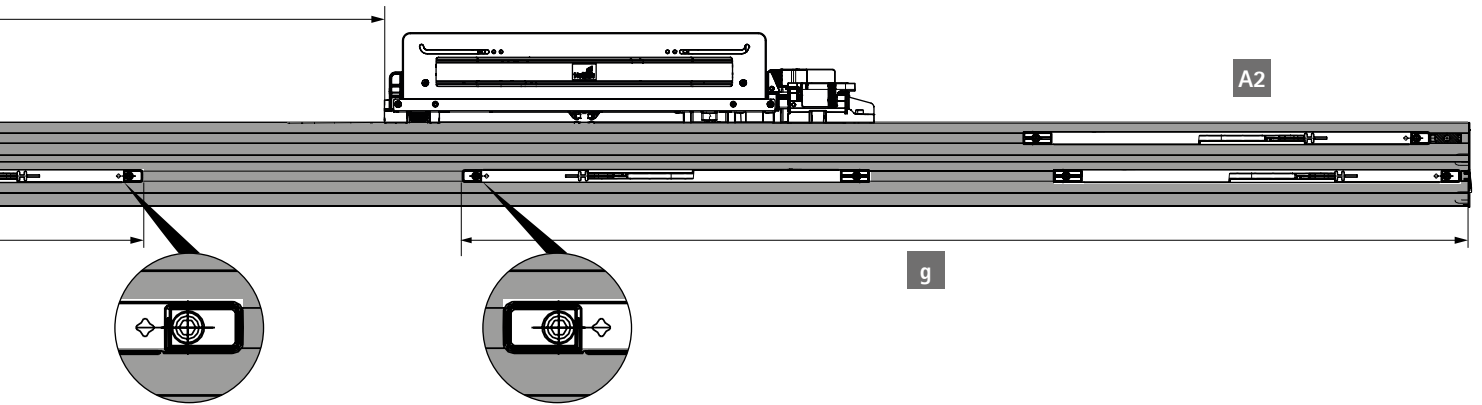
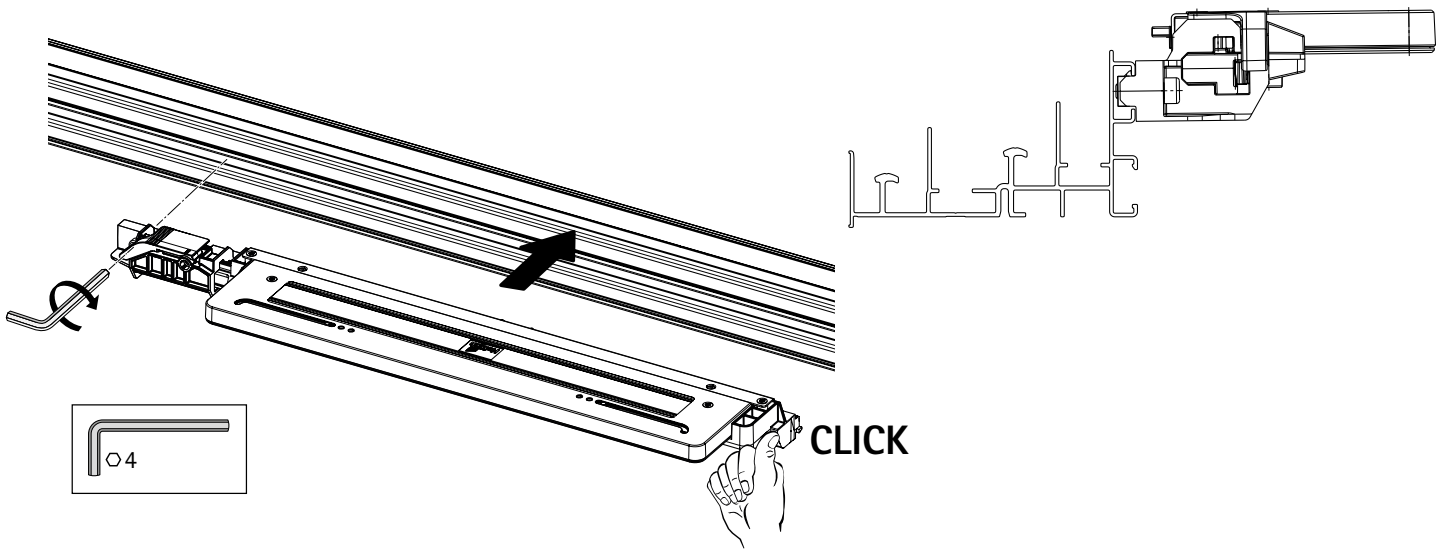



B

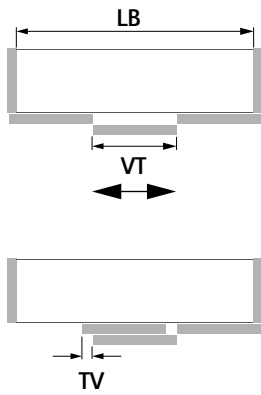
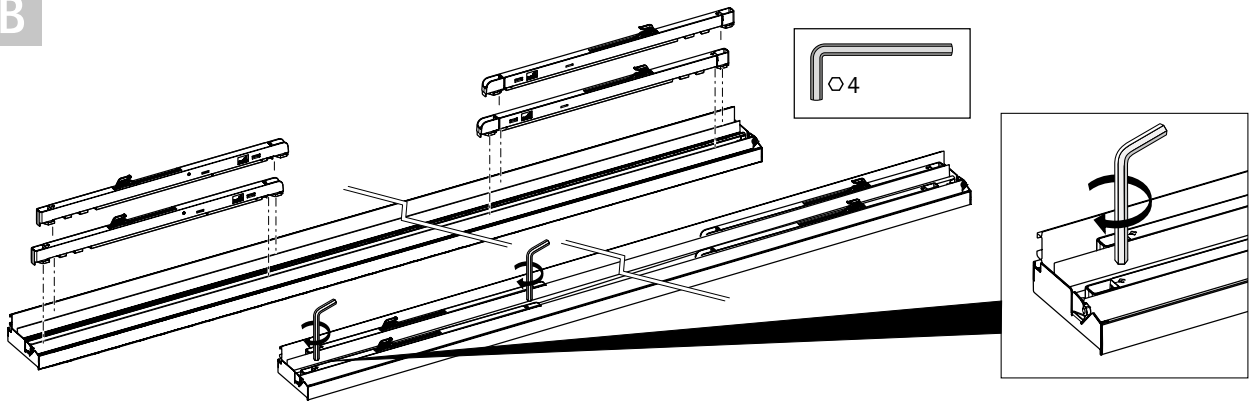

$$f = \frac{\left(\text{LB} + \text{VT} \right)}{2} - 516$$

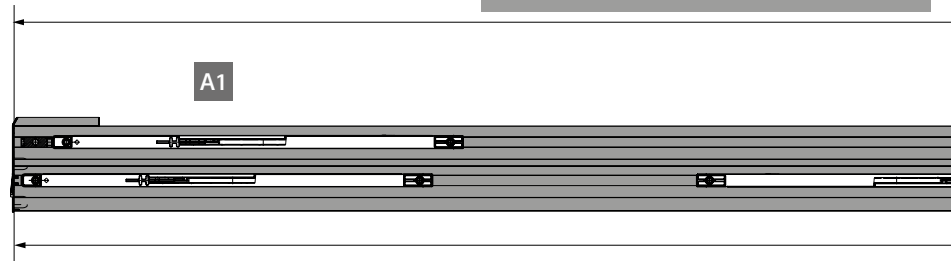

$$g = \frac{\left(\text{LB} - \text{VT} \right)}{2} - \text{TV} + 392$$

	<p>±0</p>	<p>A1</p> <p>A2</p>
<p>34</p>	<p>A1</p> <p>A2</p>	
<p>68</p>	<p>A1</p> <p>A2</p>	

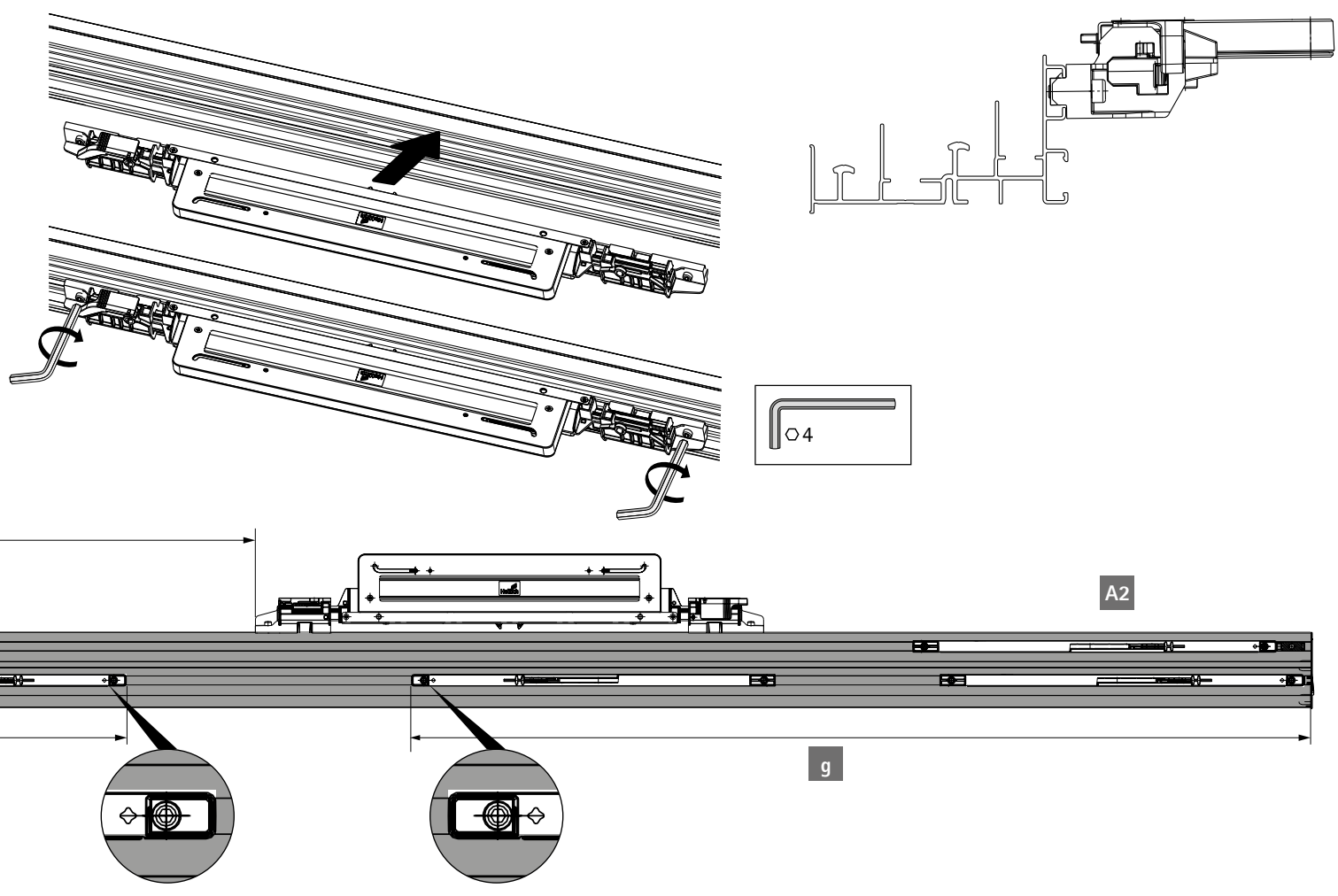



C

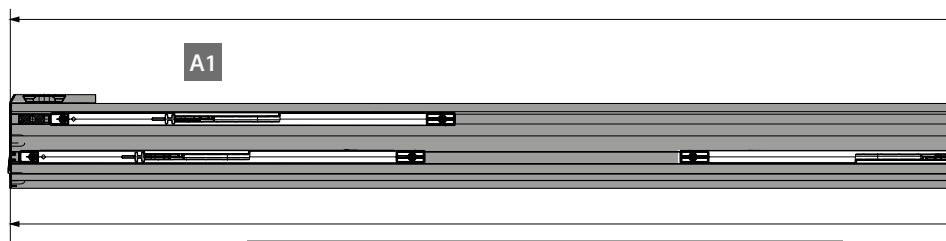
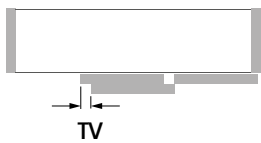
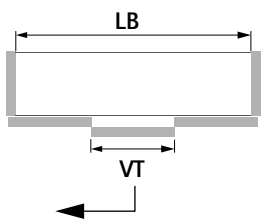
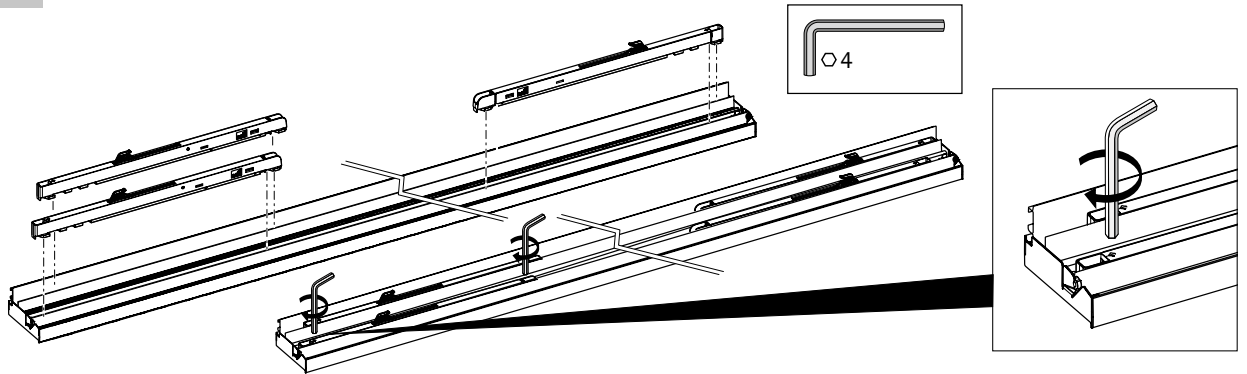

$$g = \frac{LB - VT}{2} - TV + 392$$

	<p>+0</p>	<p>A1</p> <p>A2</p>
<p>34</p>	<p>A1</p> <p>A2</p>	
<p>68</p>	<p>A1</p> <p>A2</p>	

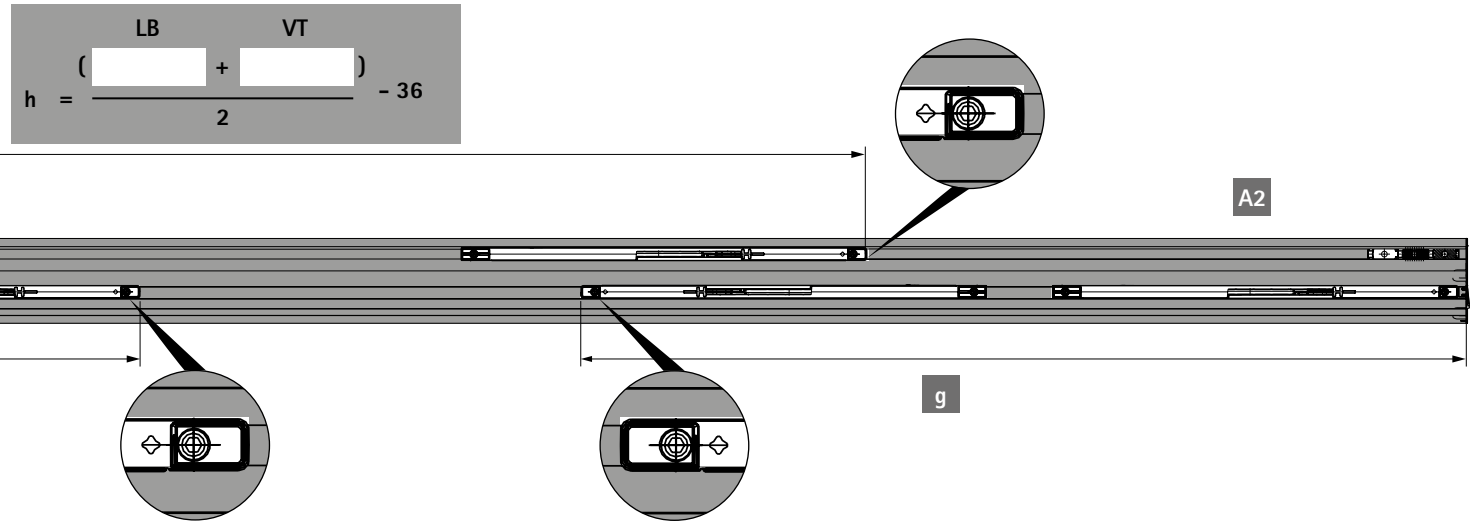



D

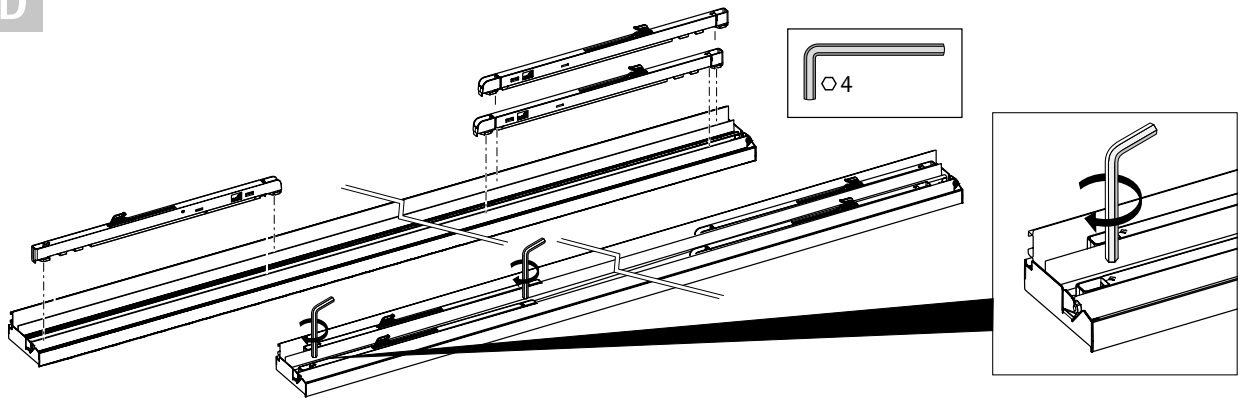

$$h = \frac{(\text{LB} - \text{VT})}{2} + 36$$

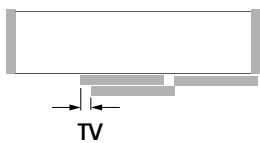
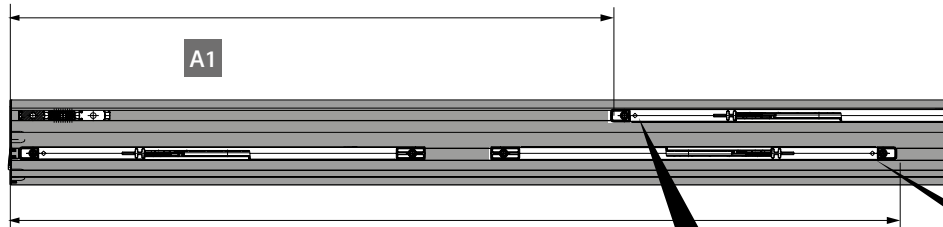
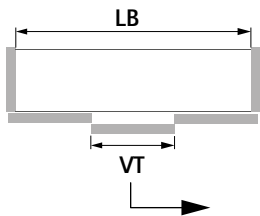

$$g = \frac{(\text{LB} - \text{VT})}{2} - \text{TV} + 392$$

		A1 	A2
		A1 	A2
		A1 	A2

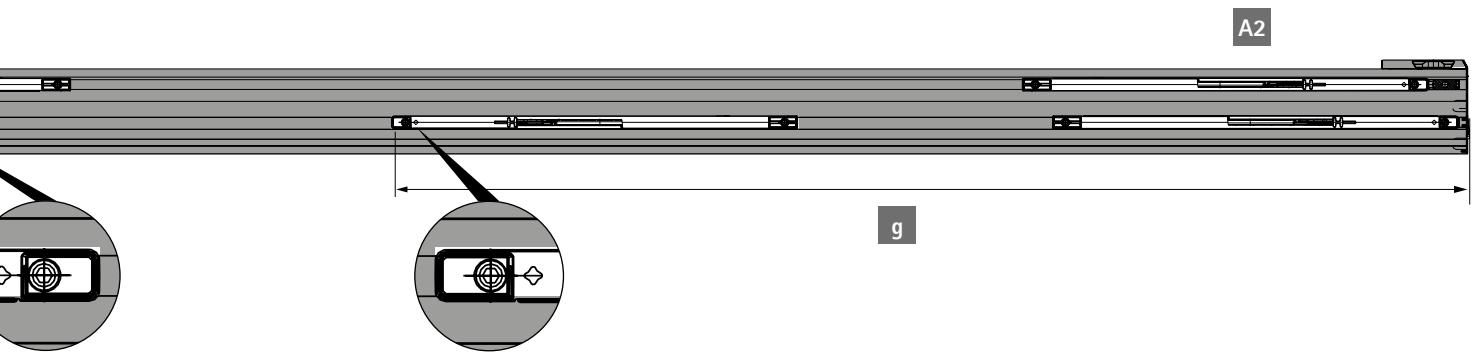

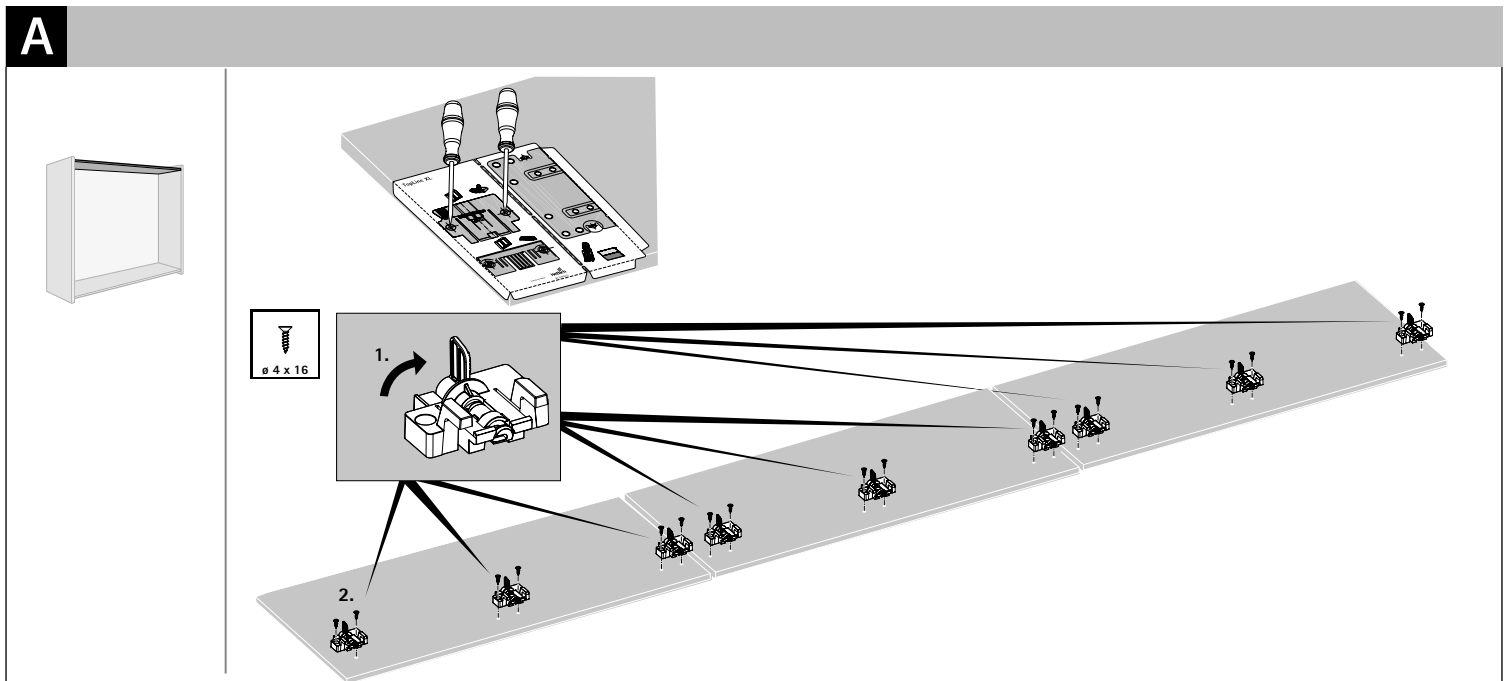
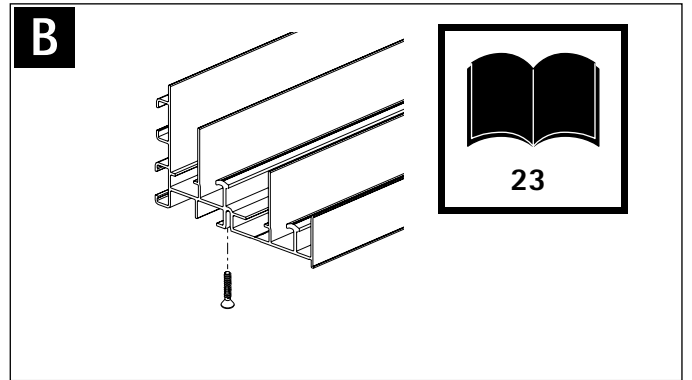
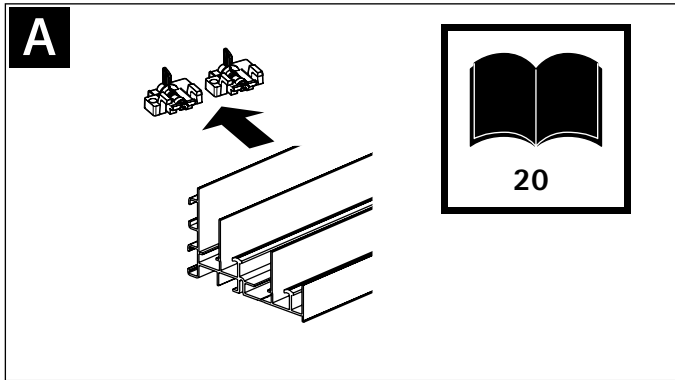
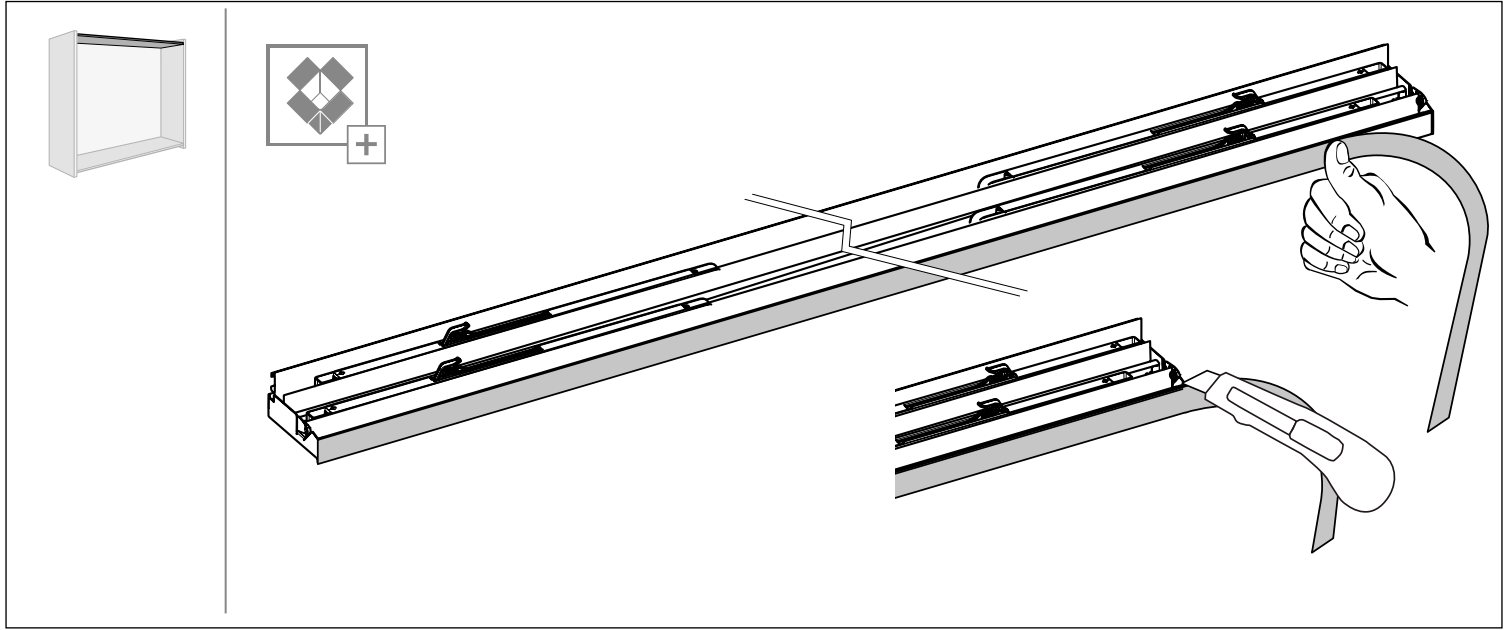

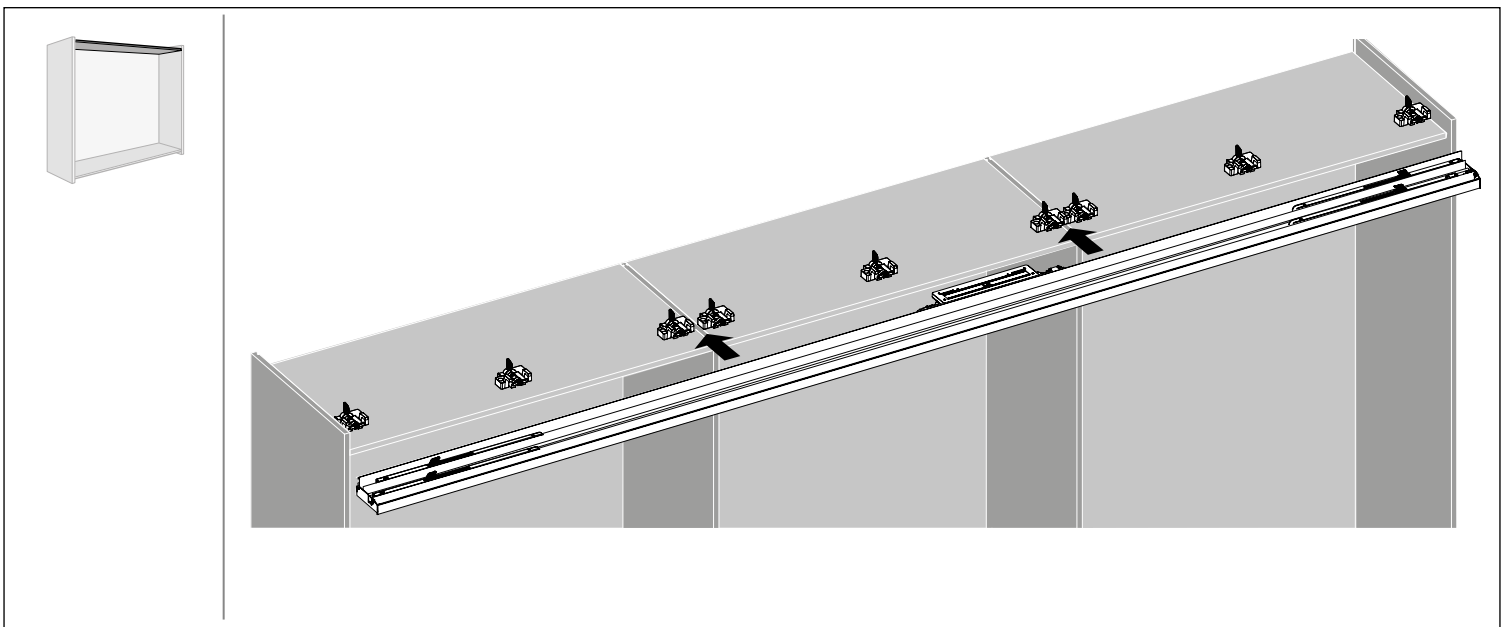
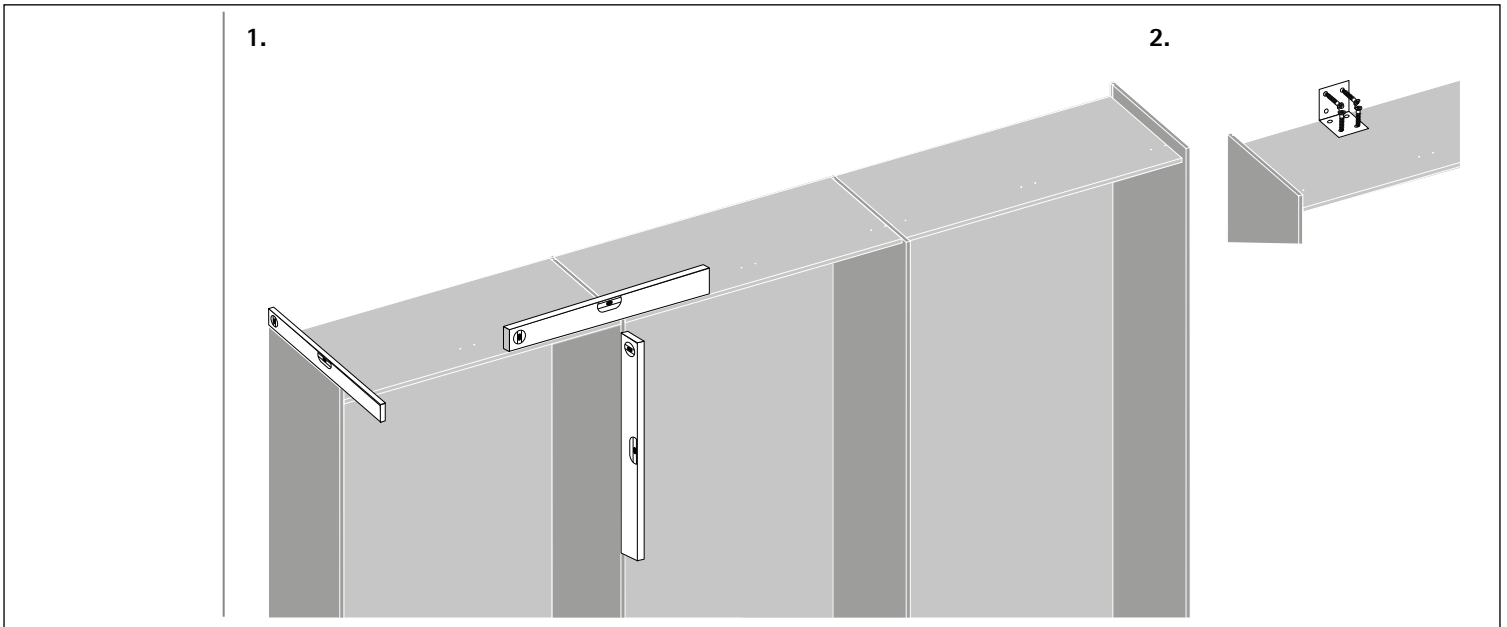
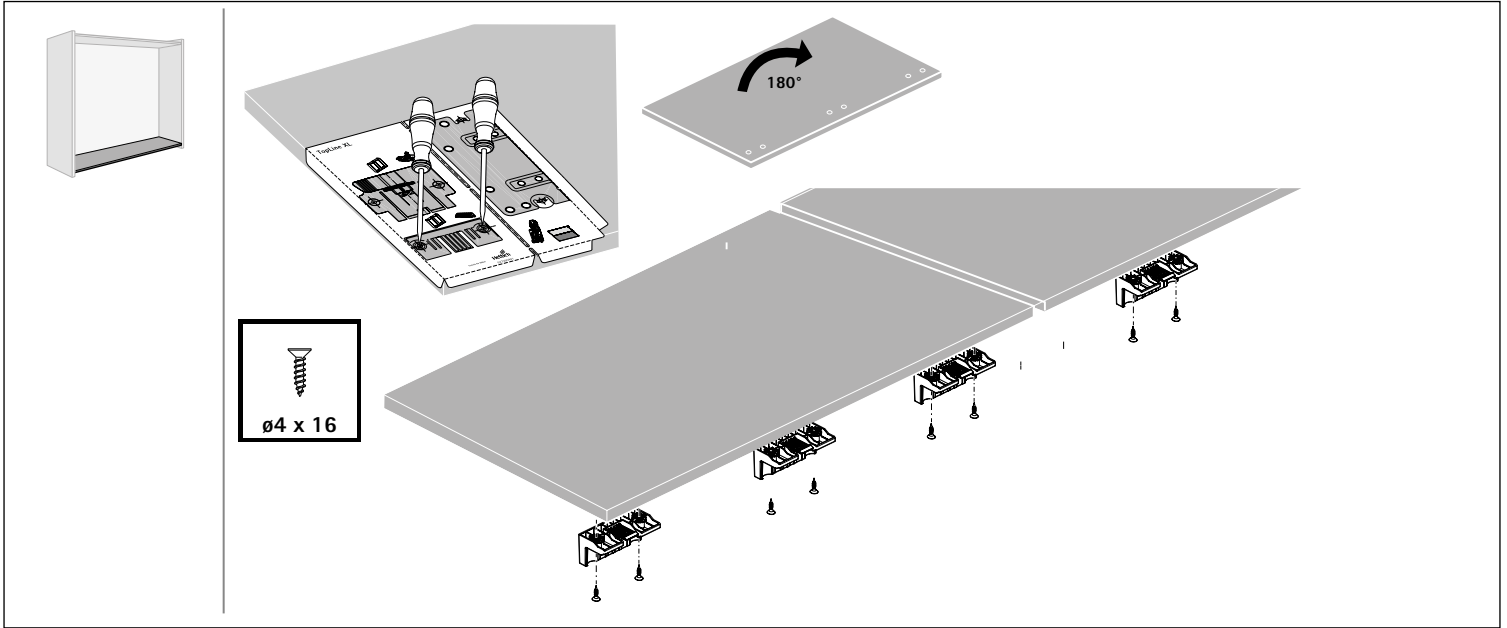

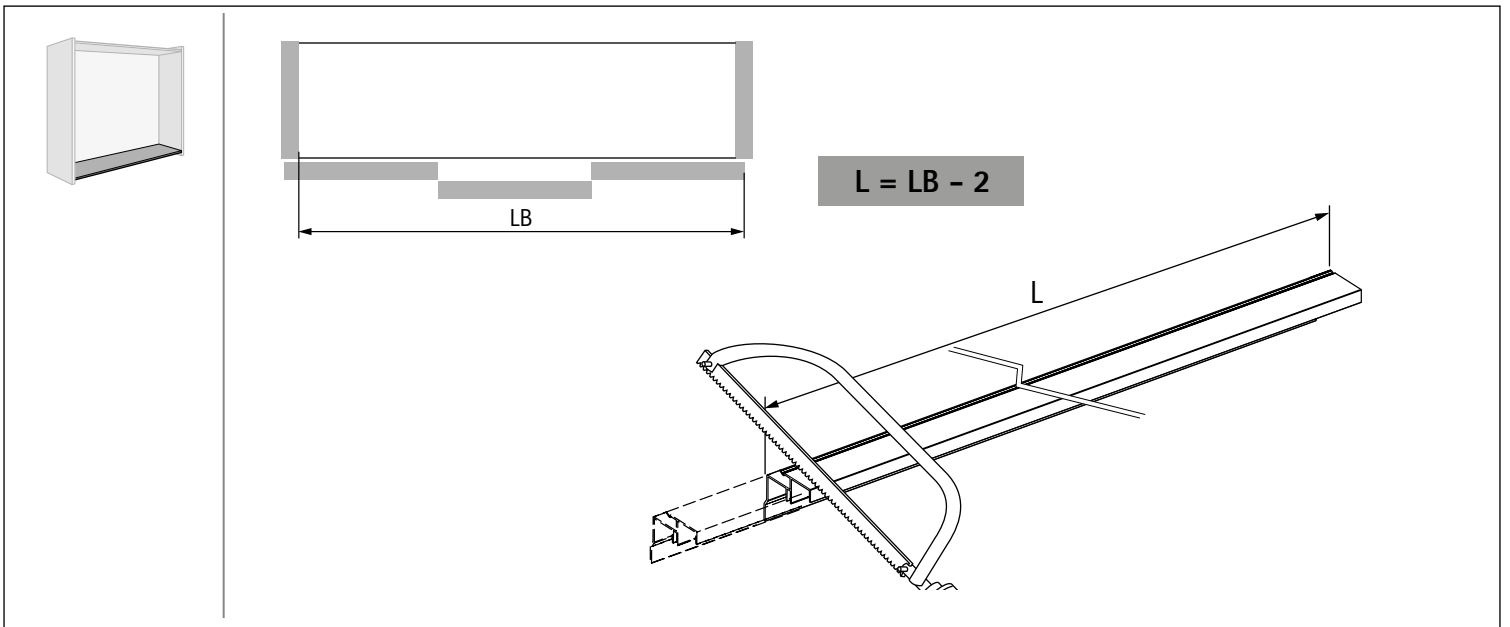
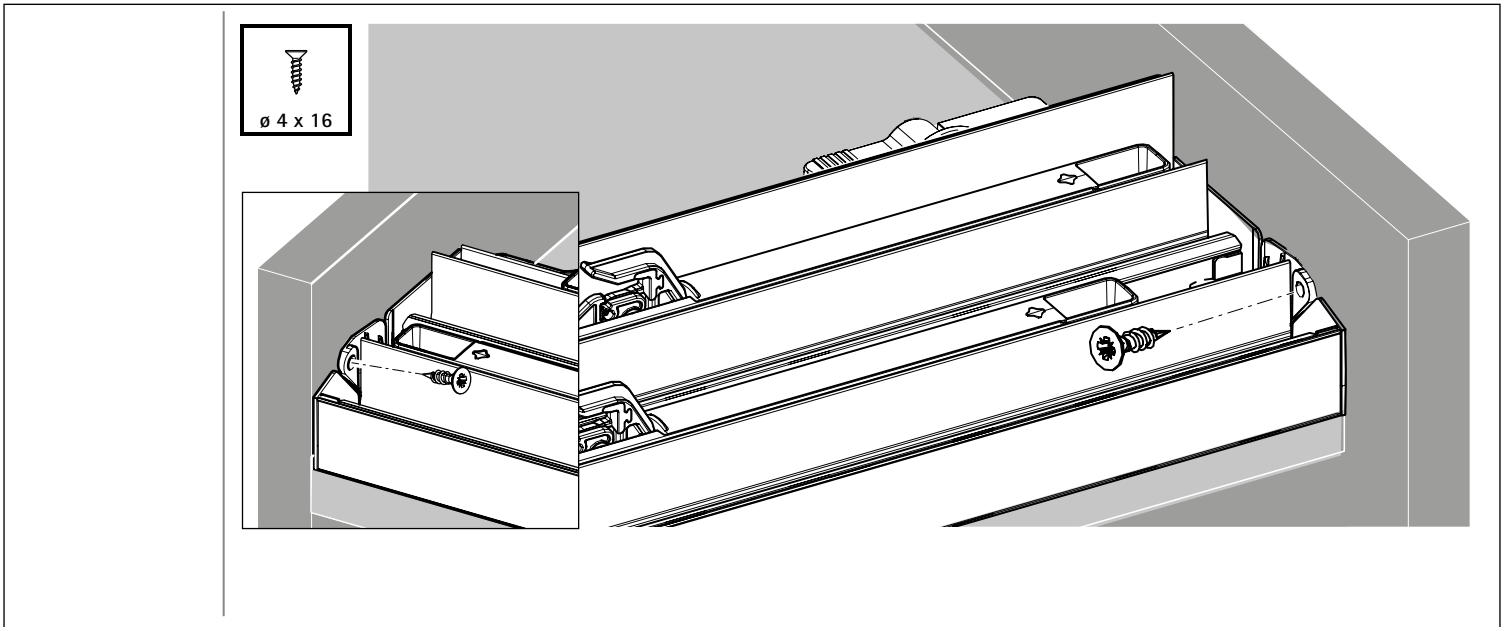
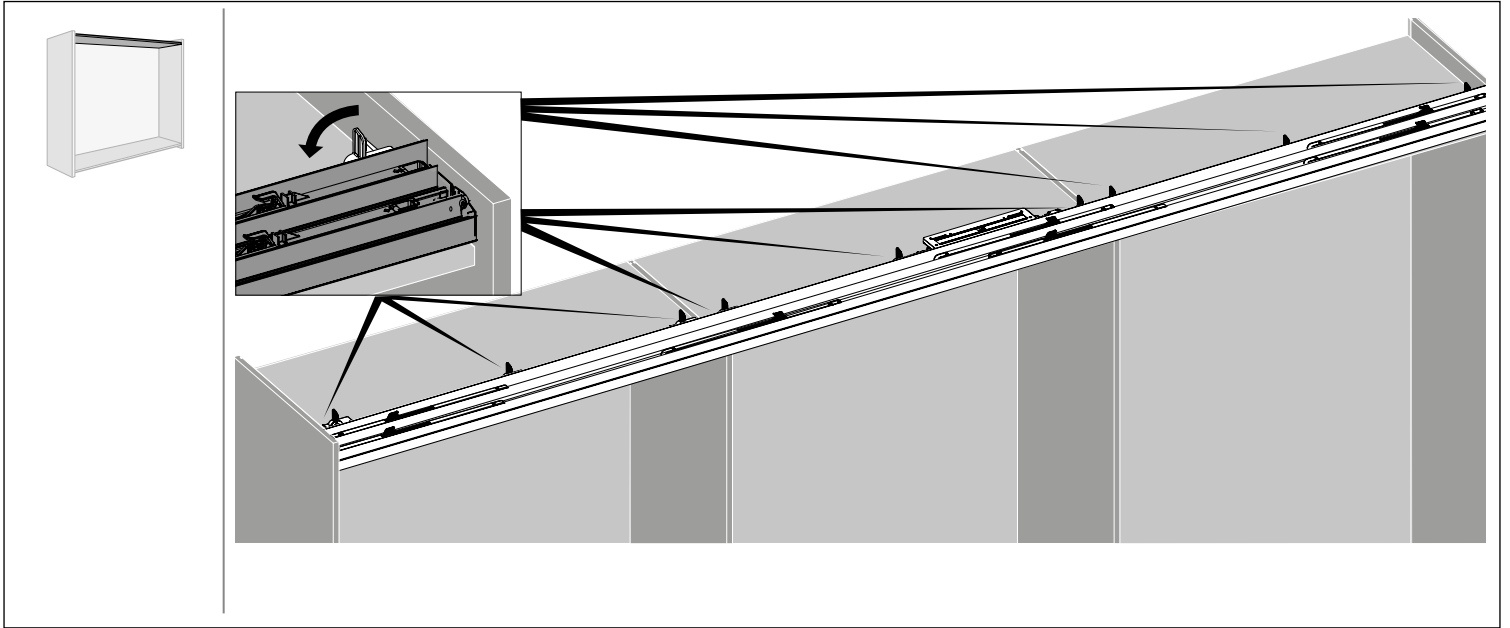

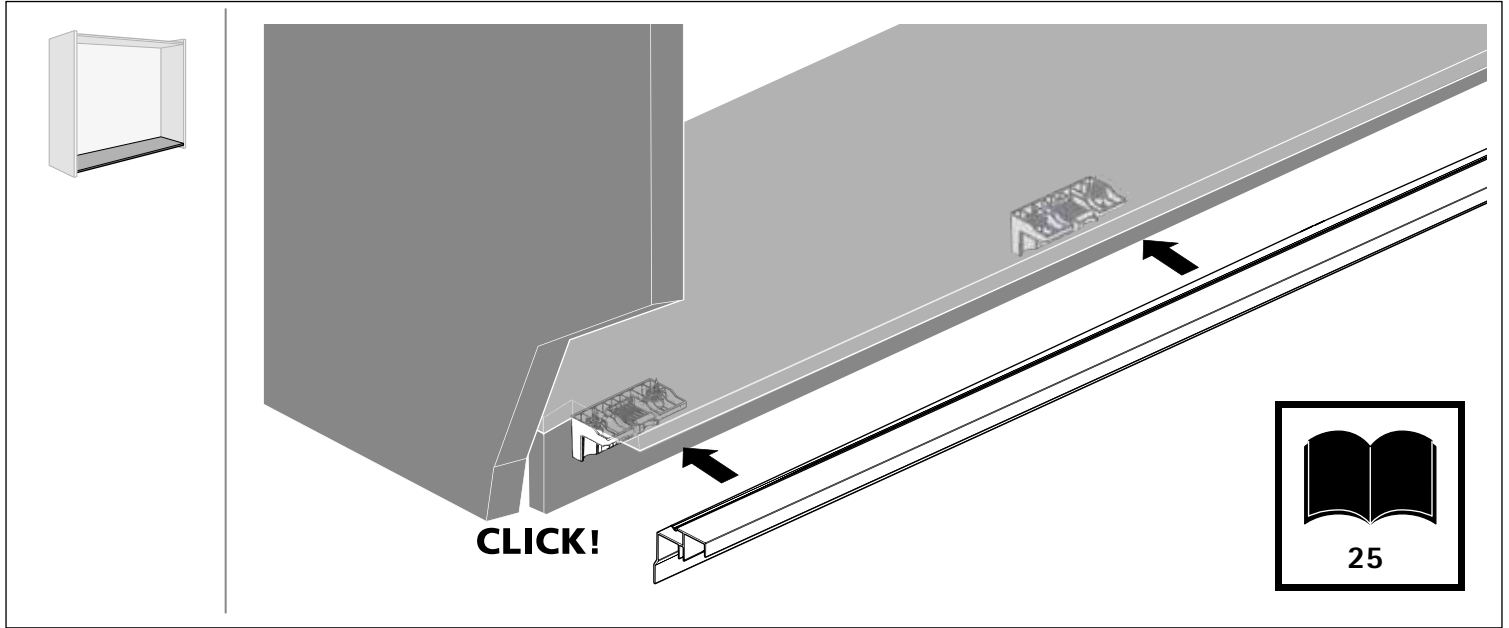

B

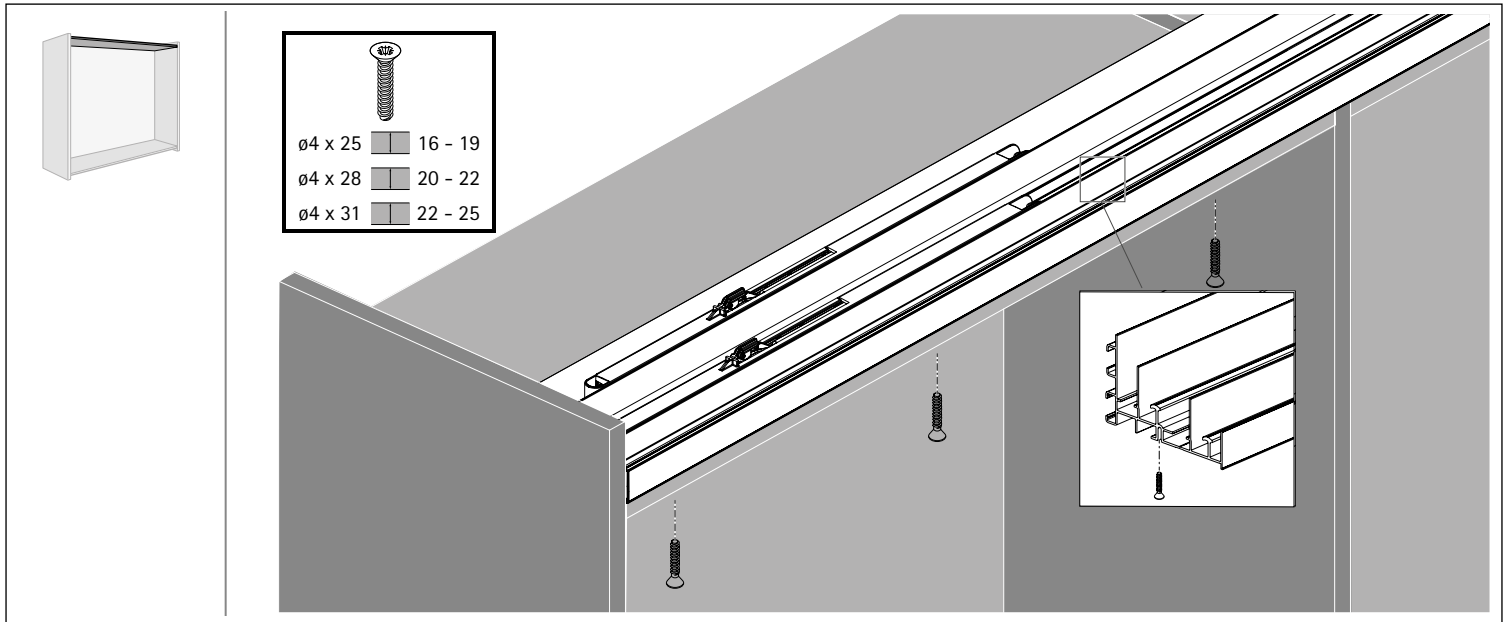
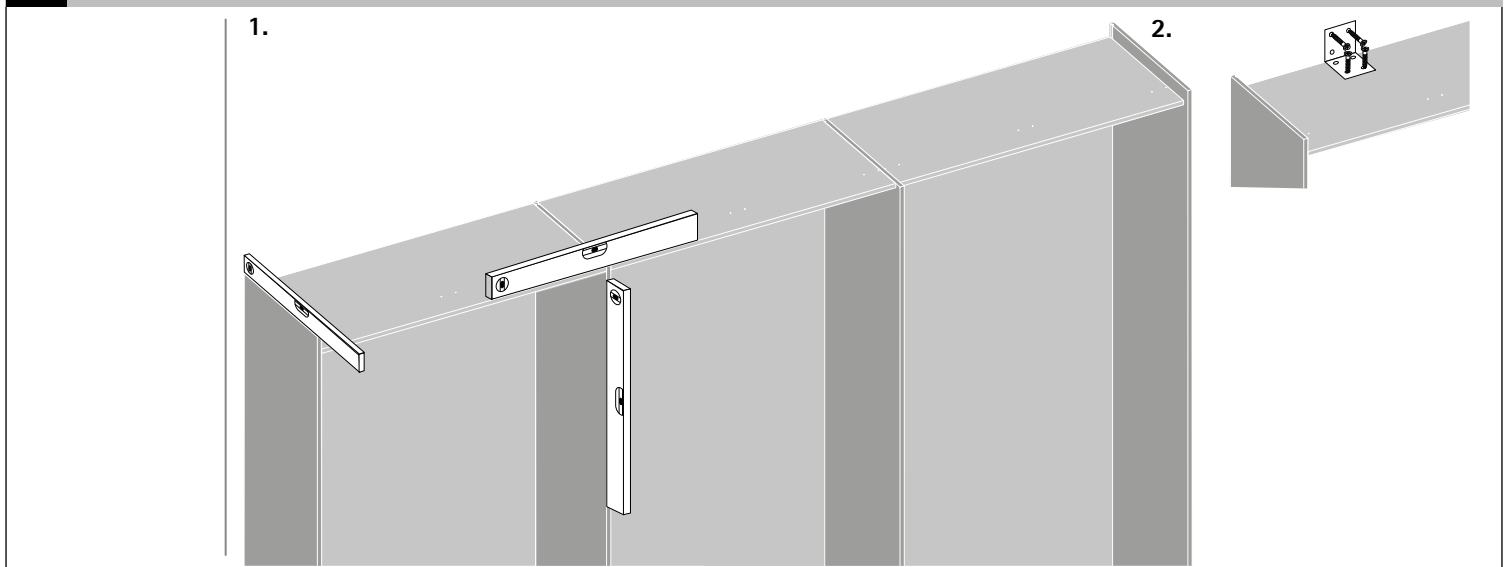

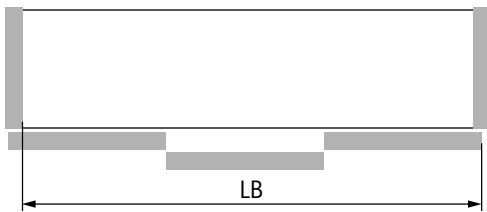
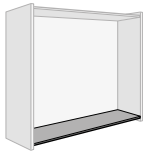
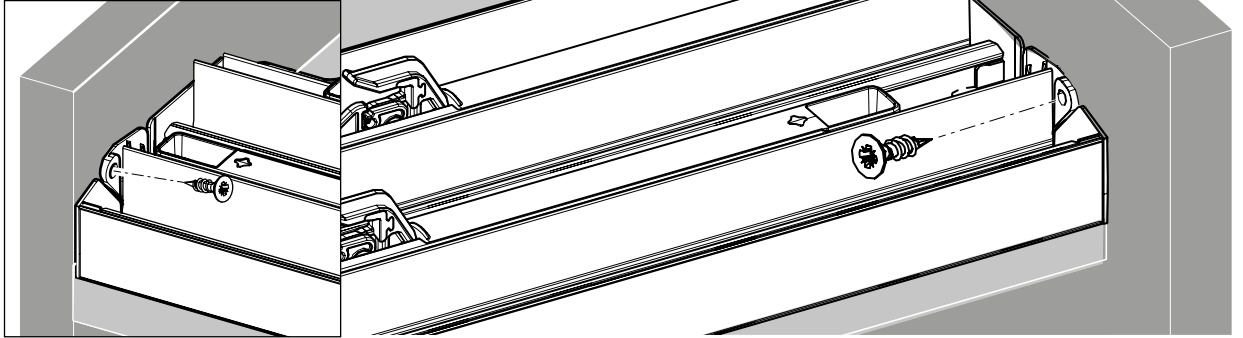

$$L = LB - 2$$

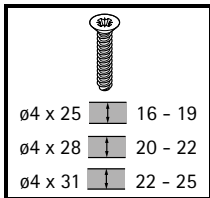
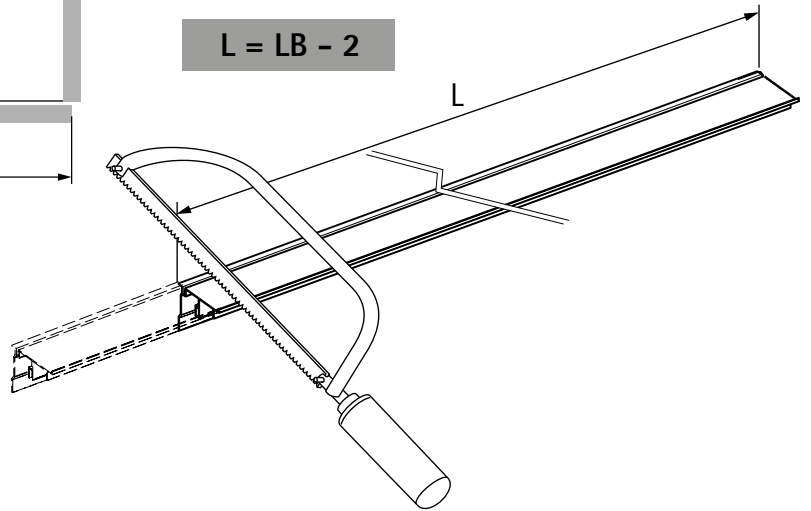

$\varnothing 4 \times 25$ 16 - 19
 $\varnothing 4 \times 28$ 20 - 22
 $\varnothing 4 \times 31$ 22 - 25

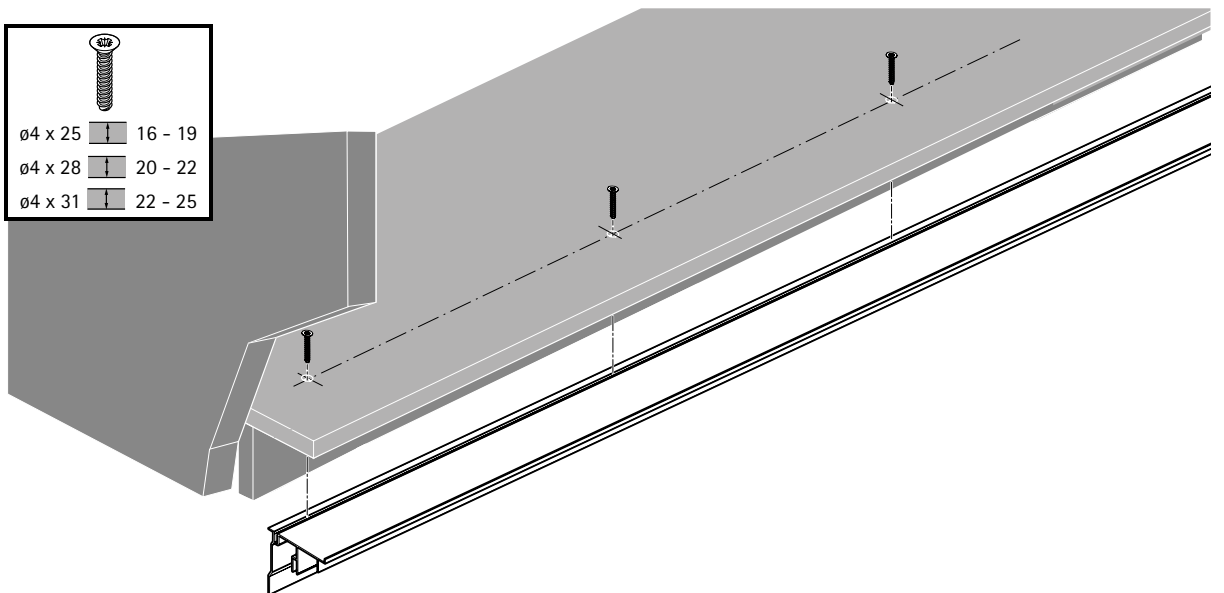

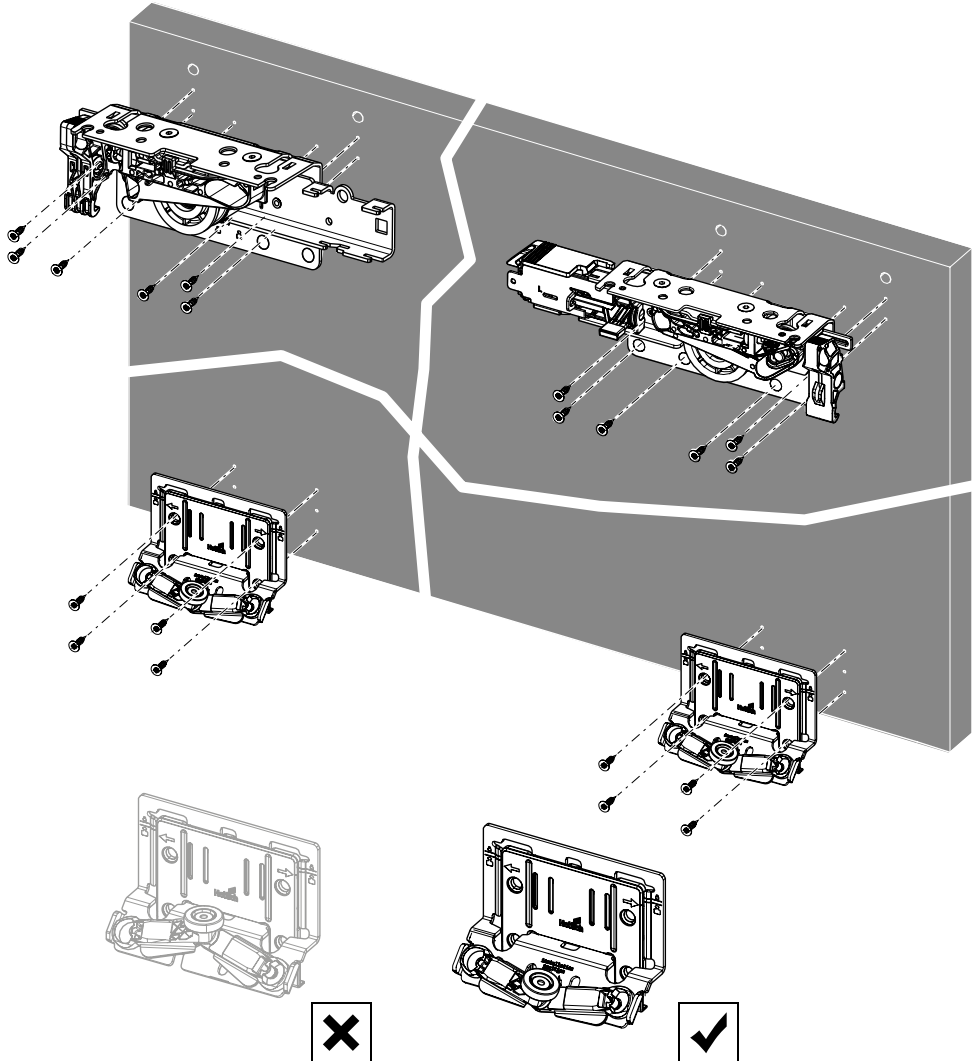
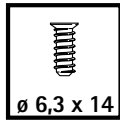
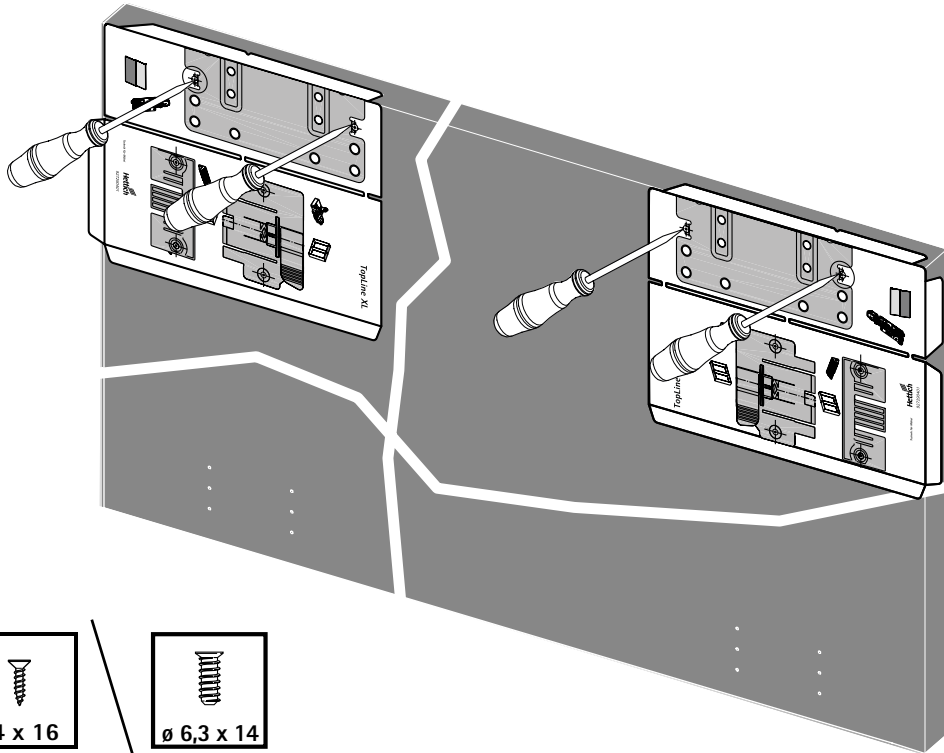
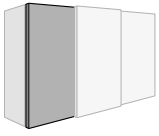

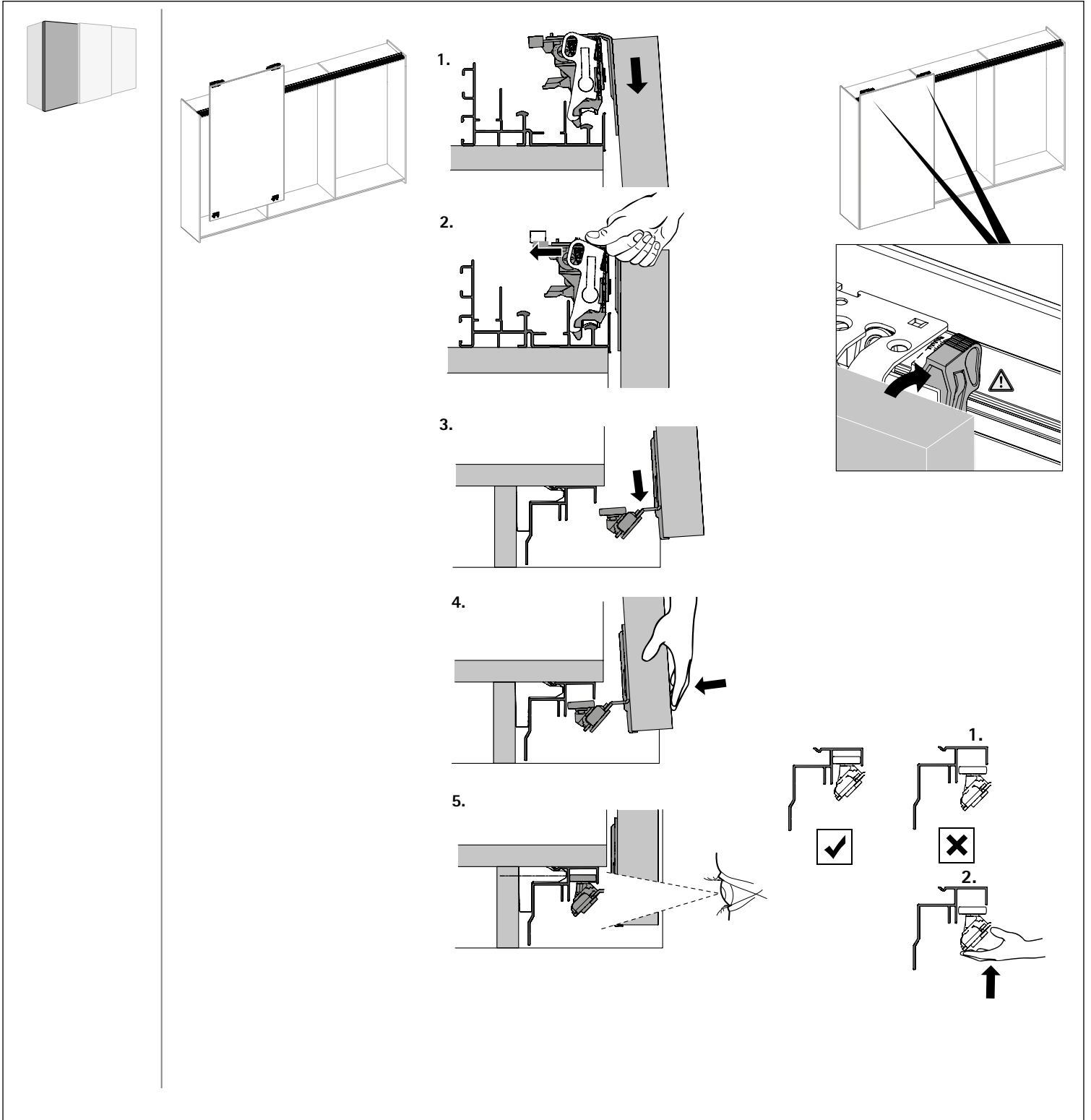
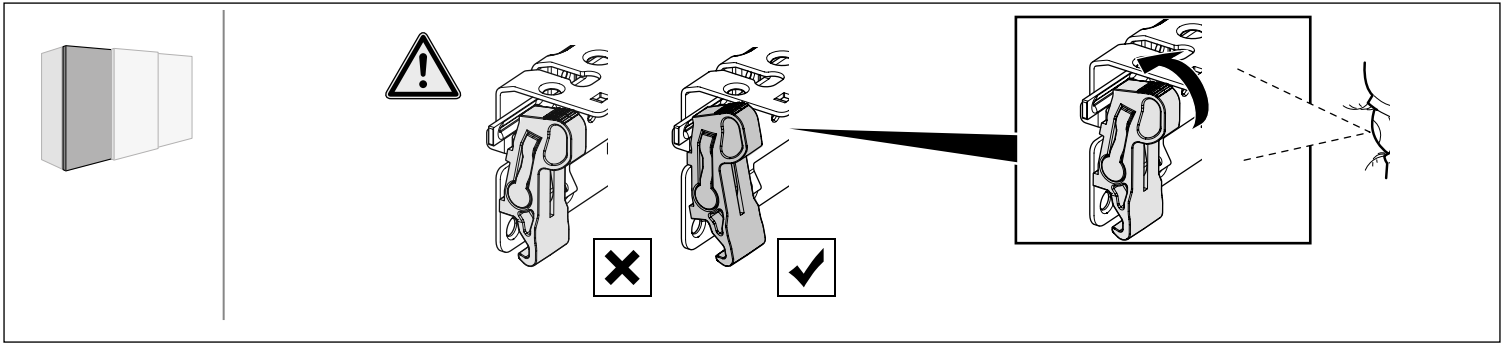

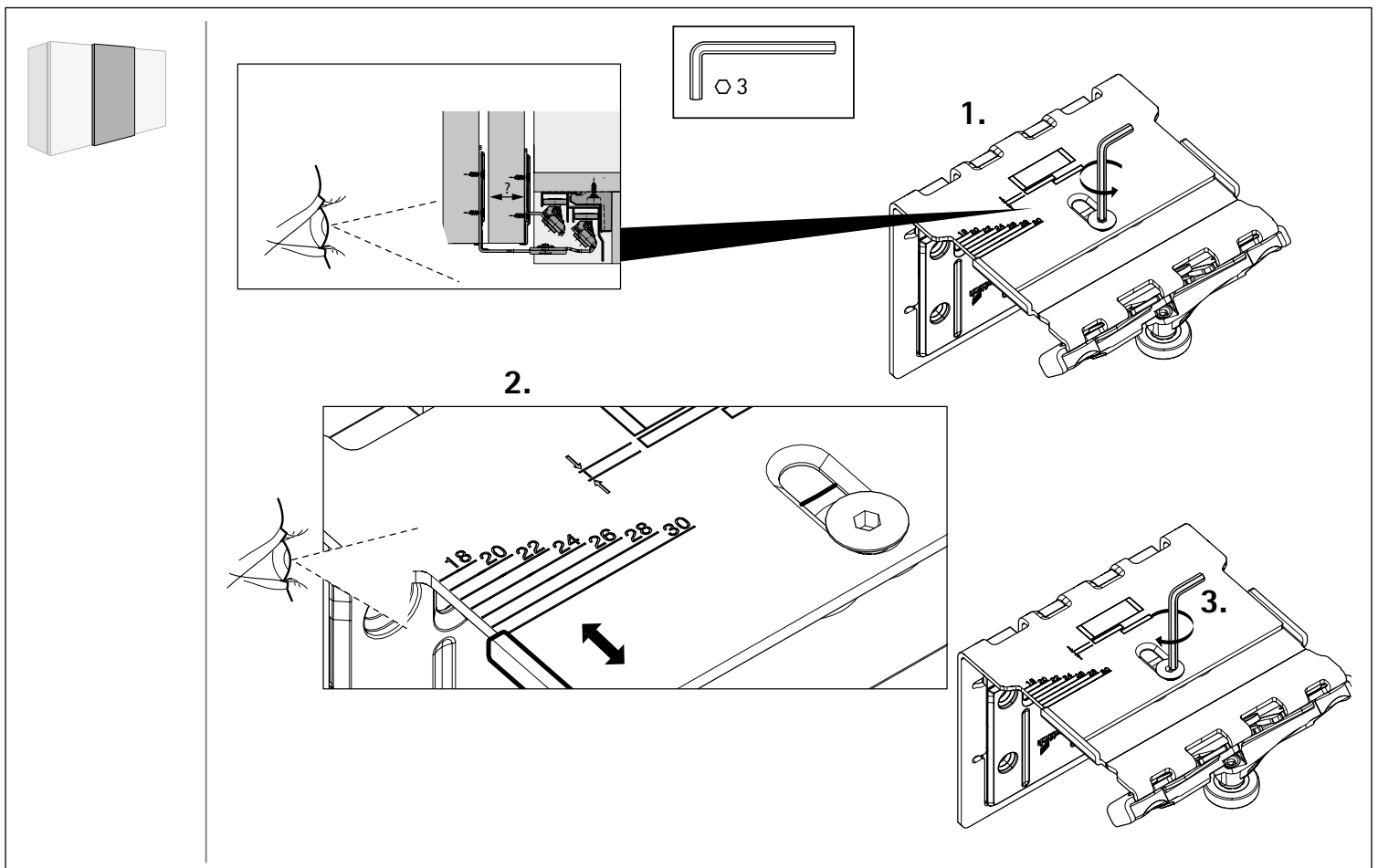
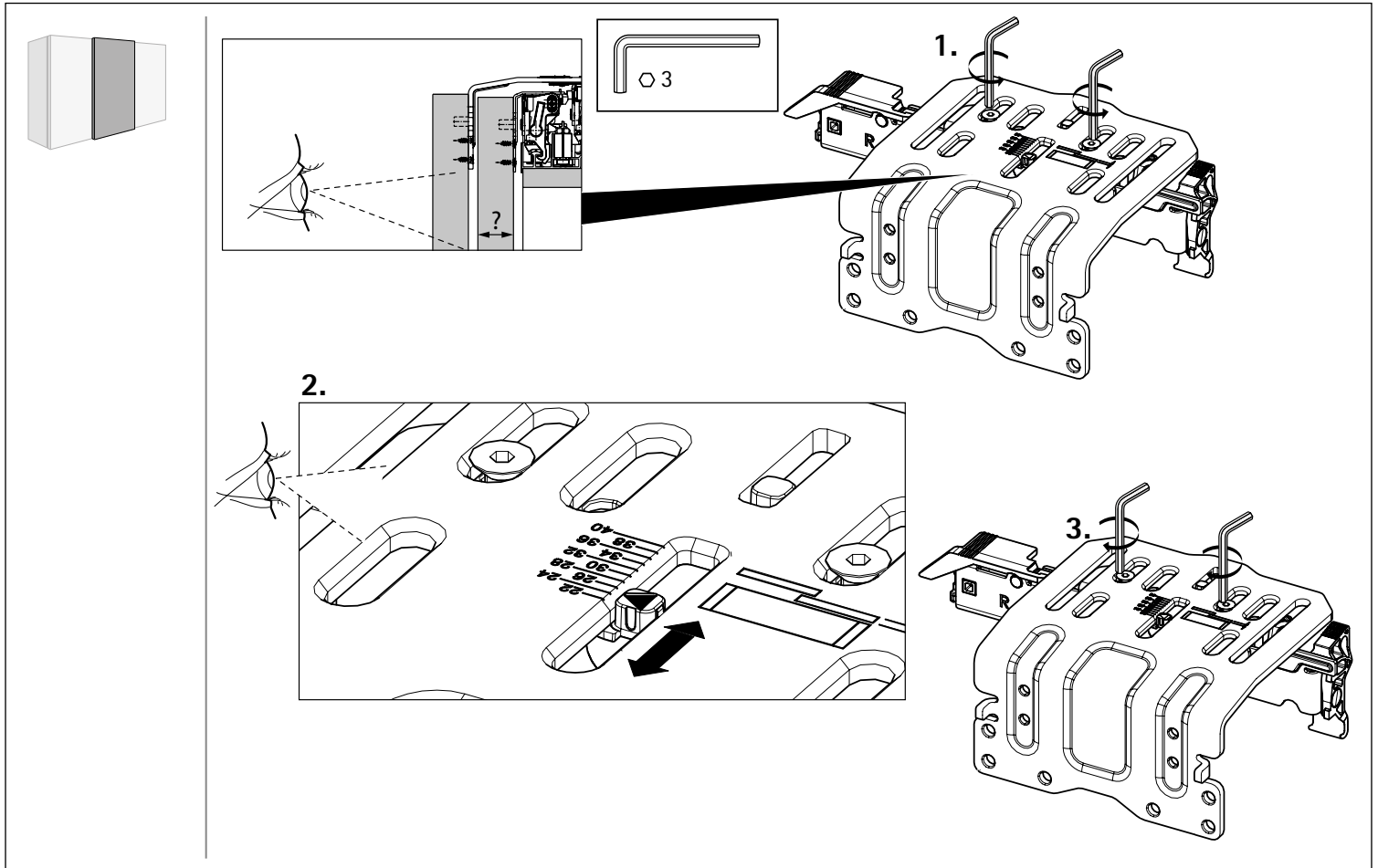

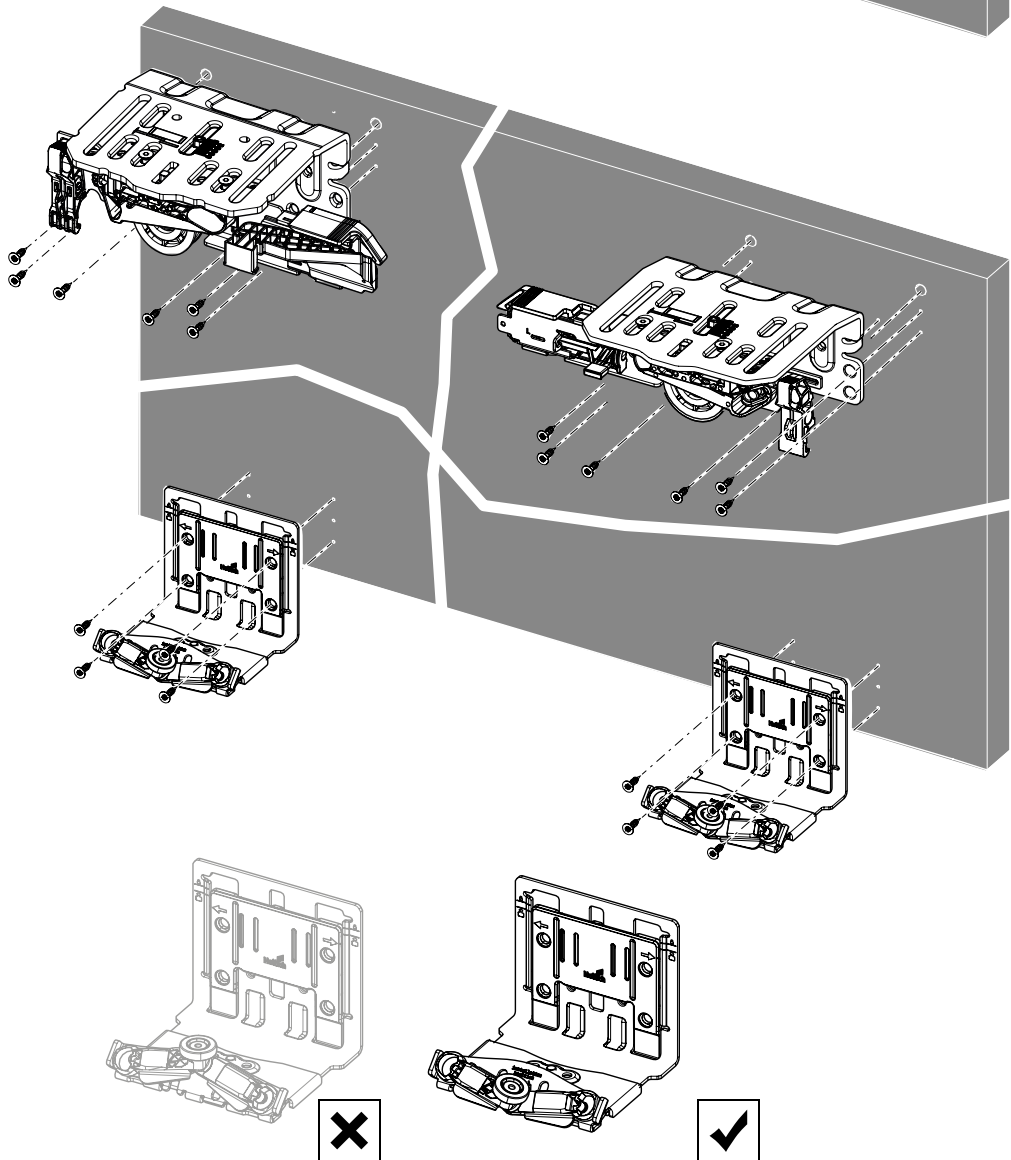
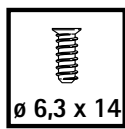
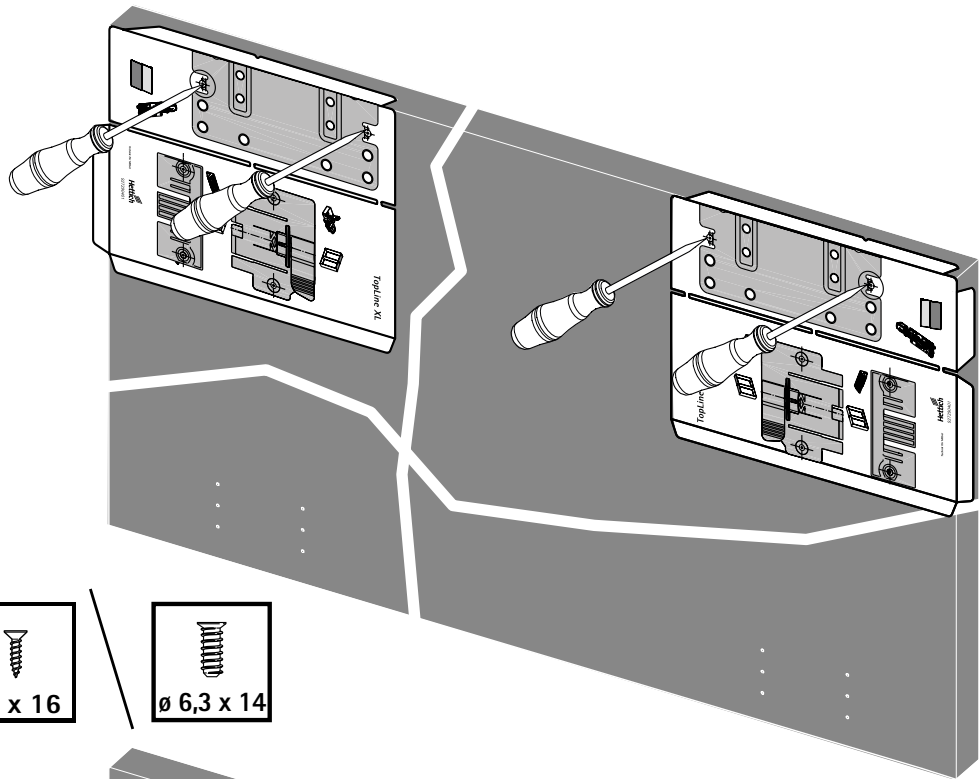
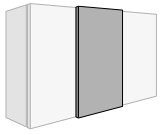

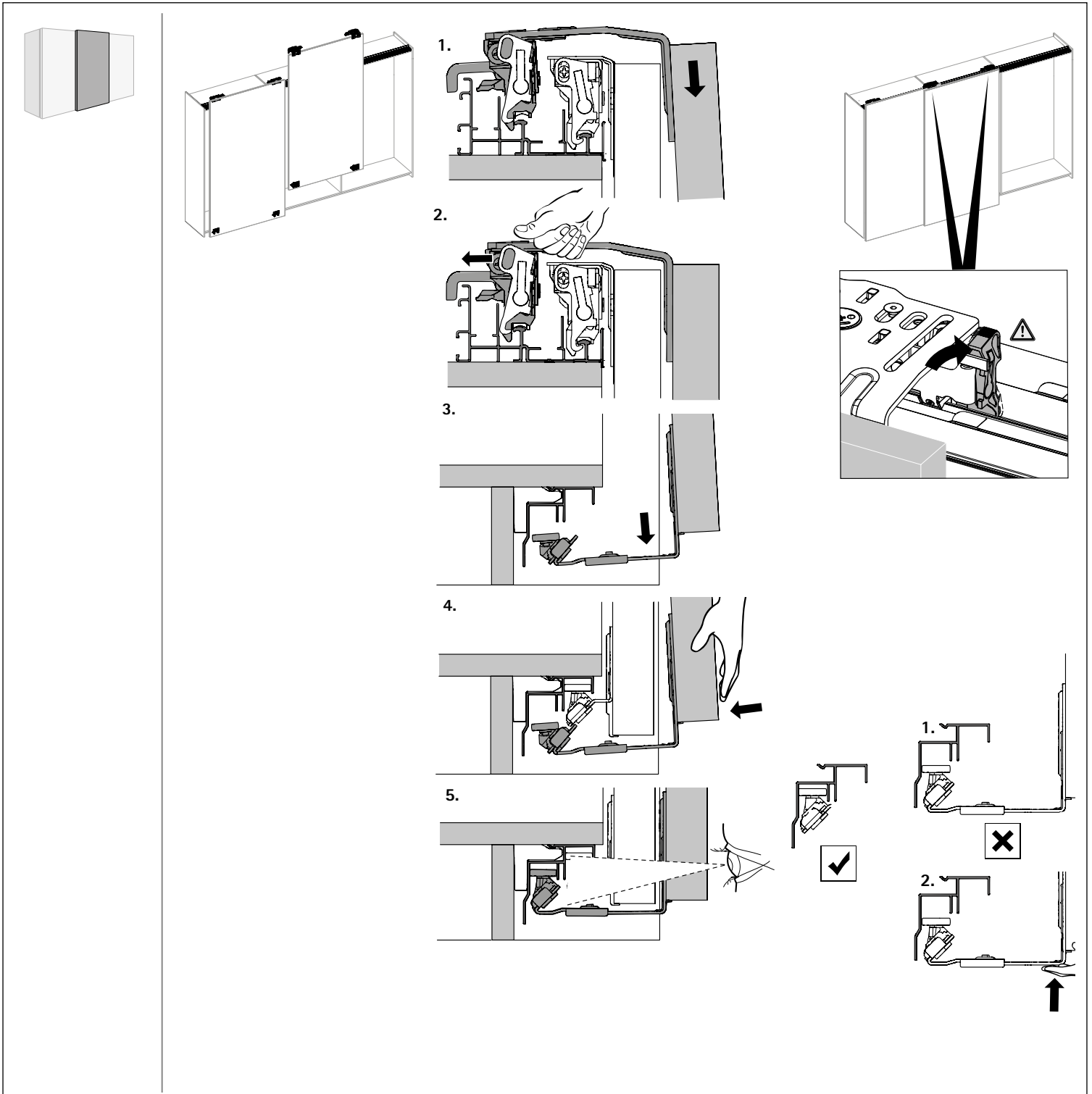
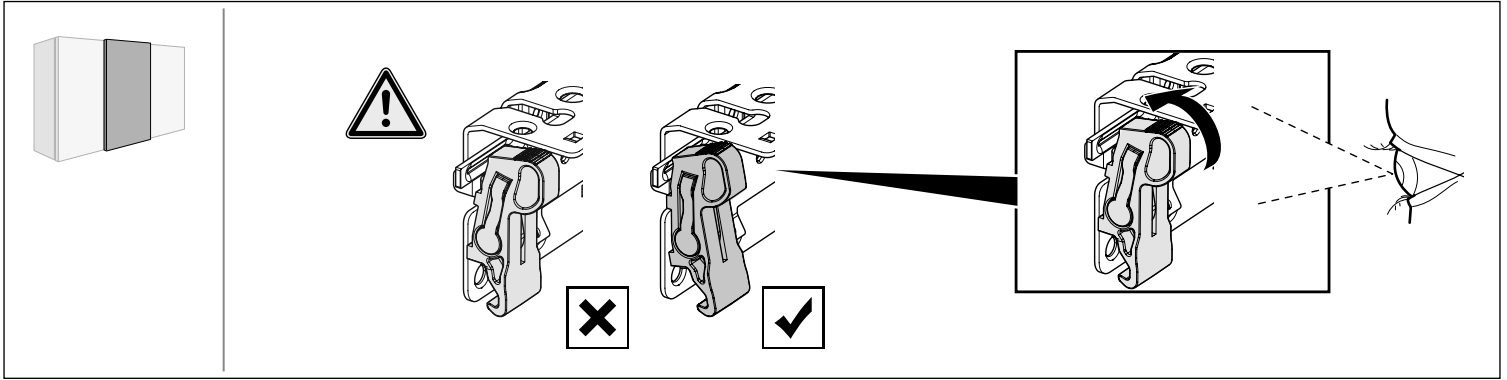

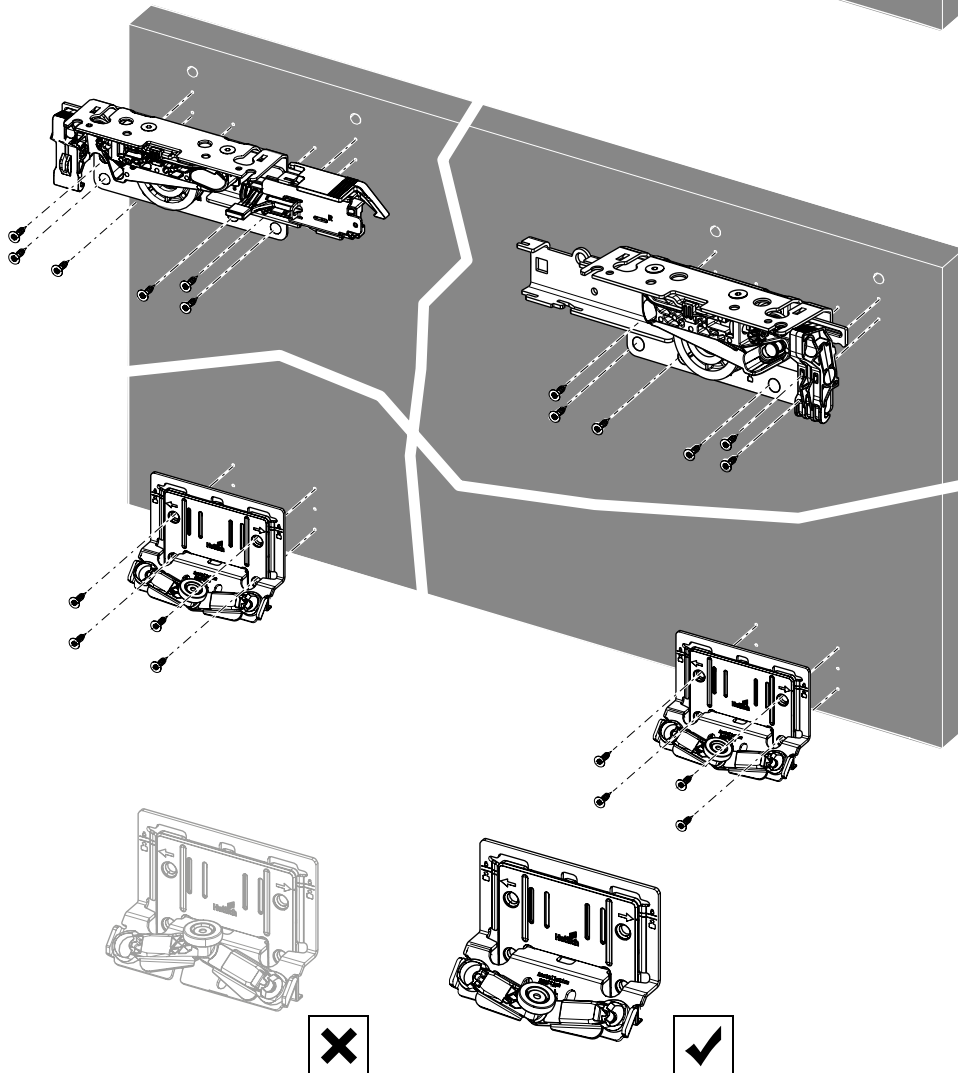
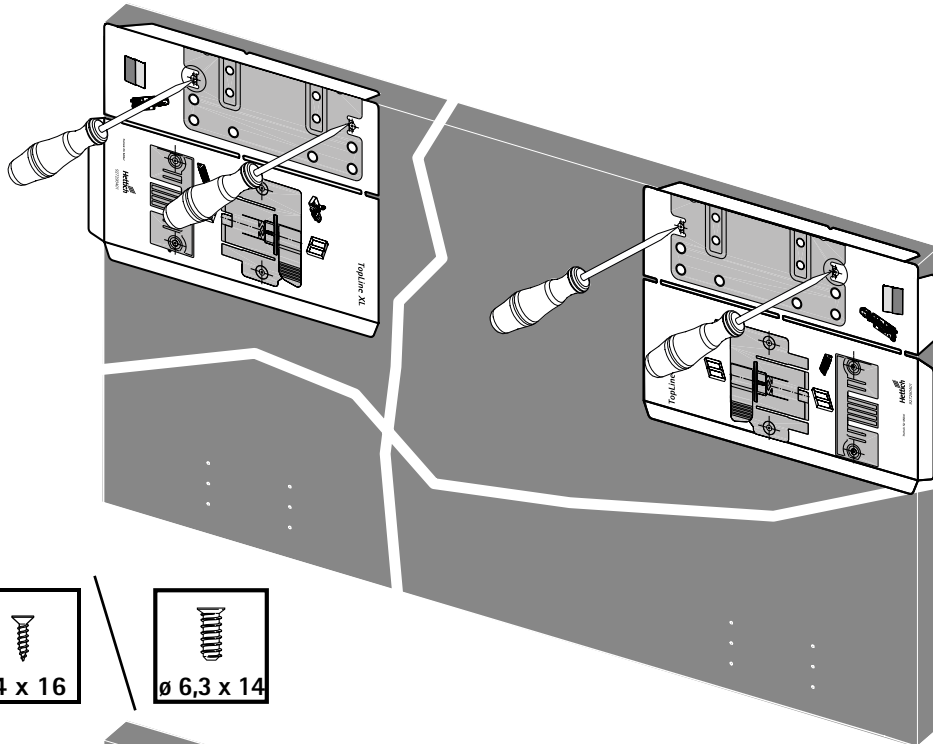
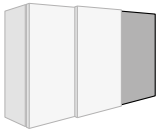

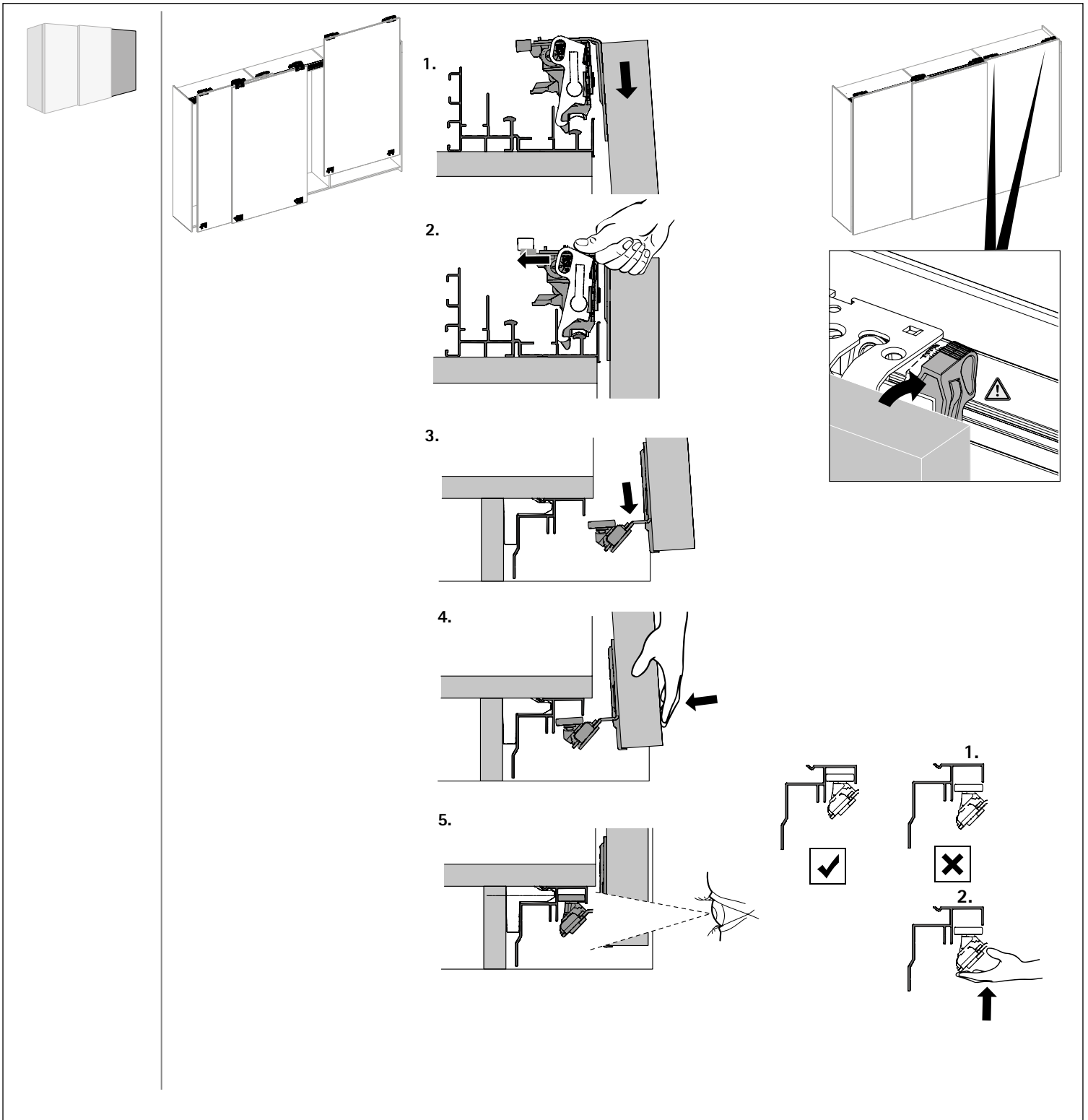
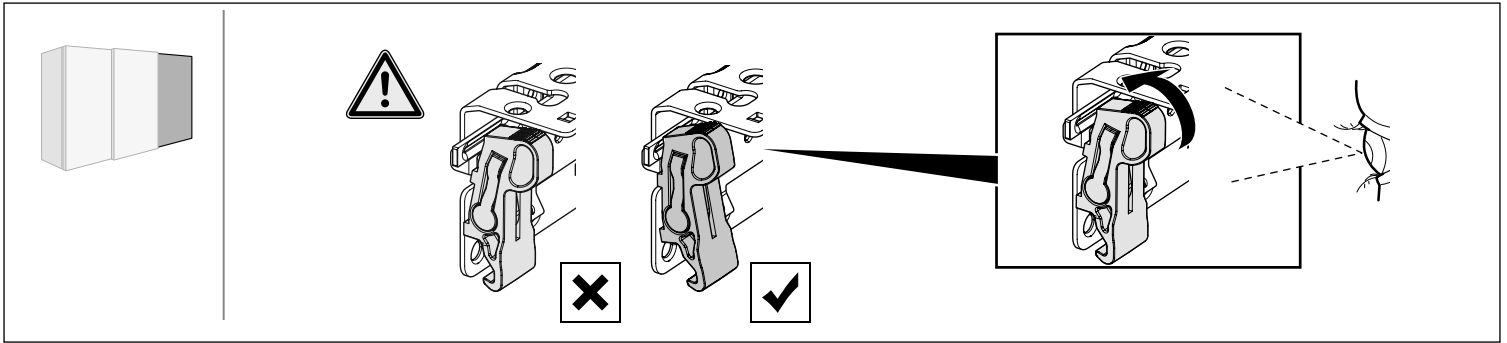



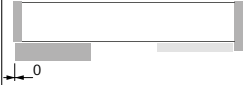

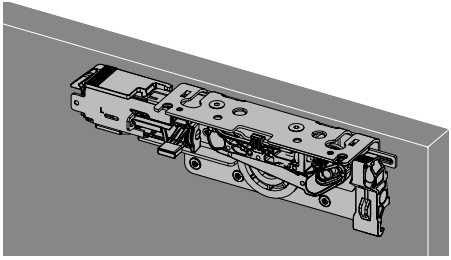



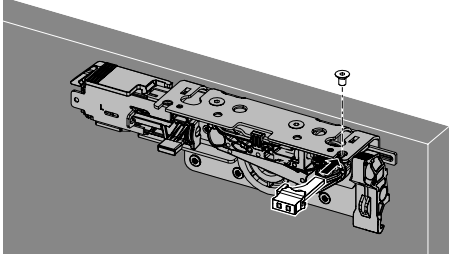
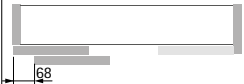

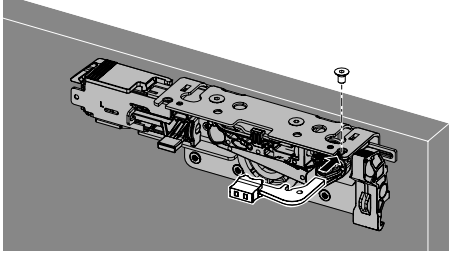

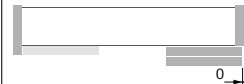

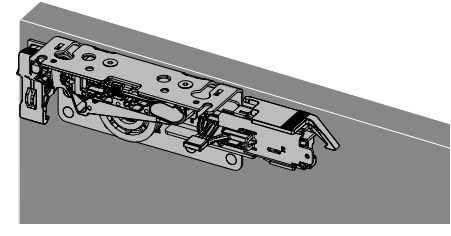

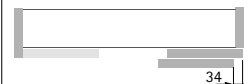

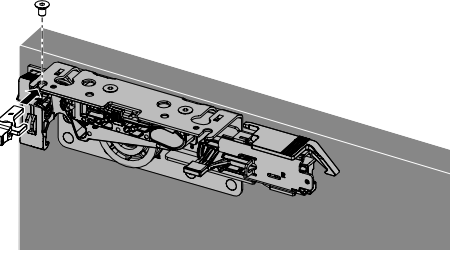

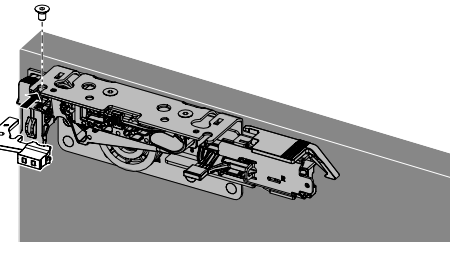

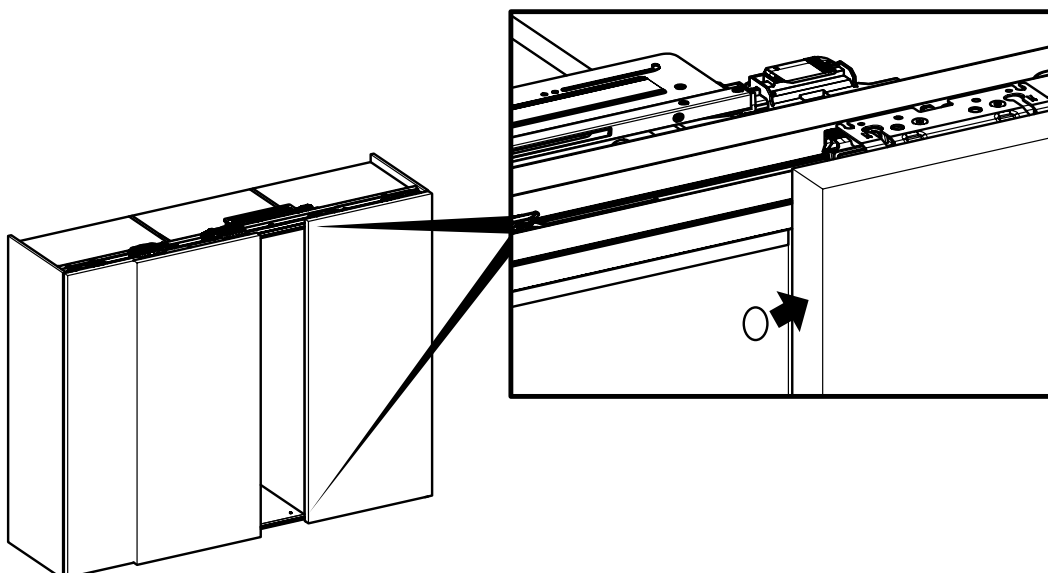
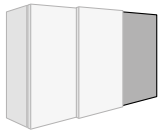
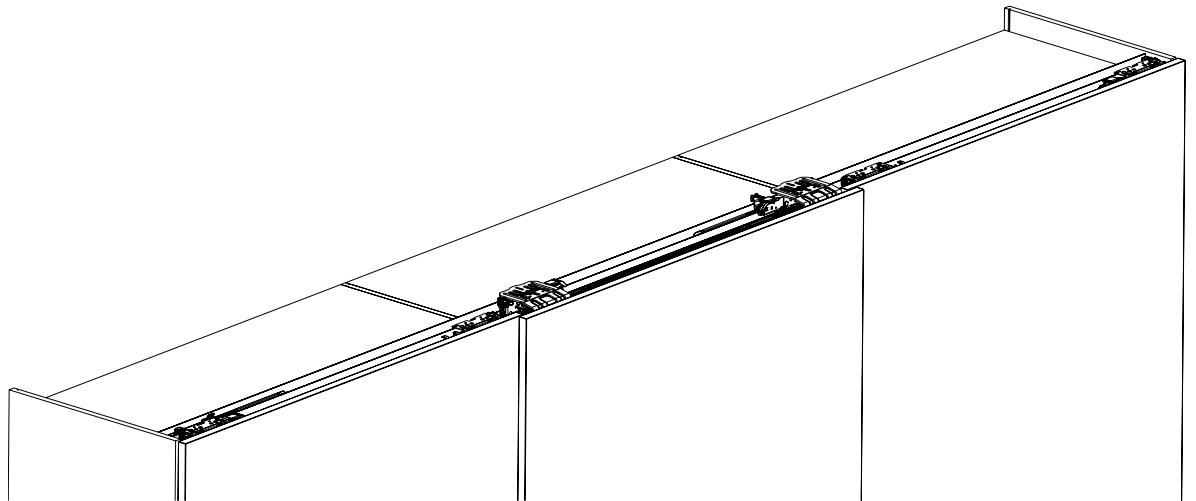
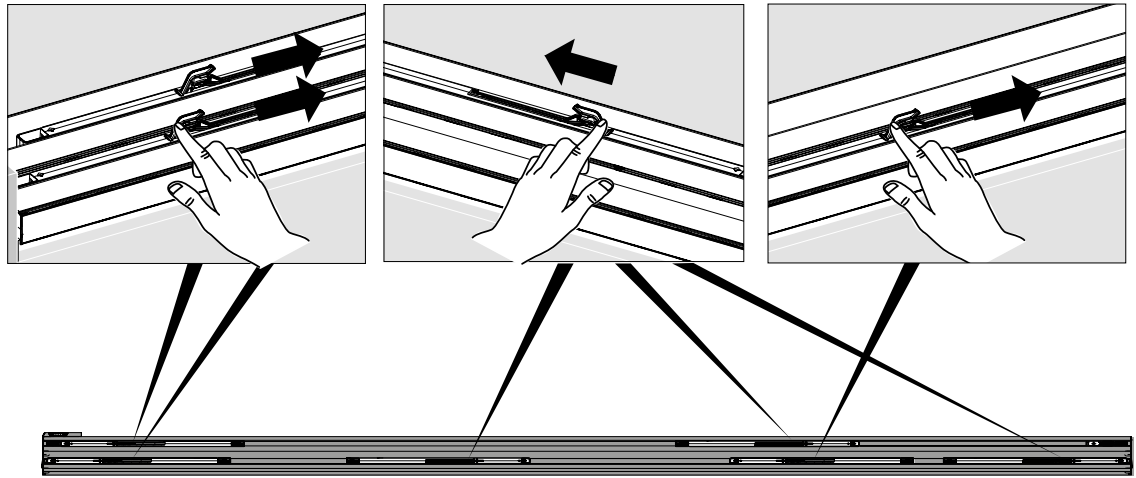

A



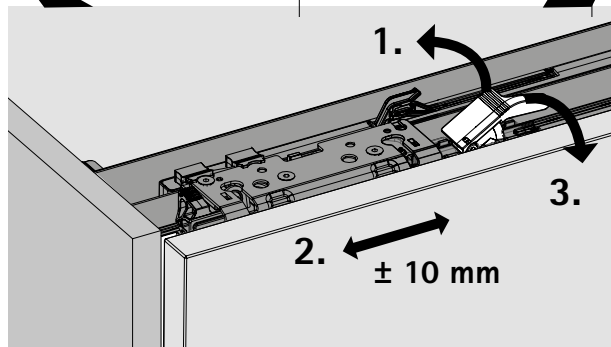
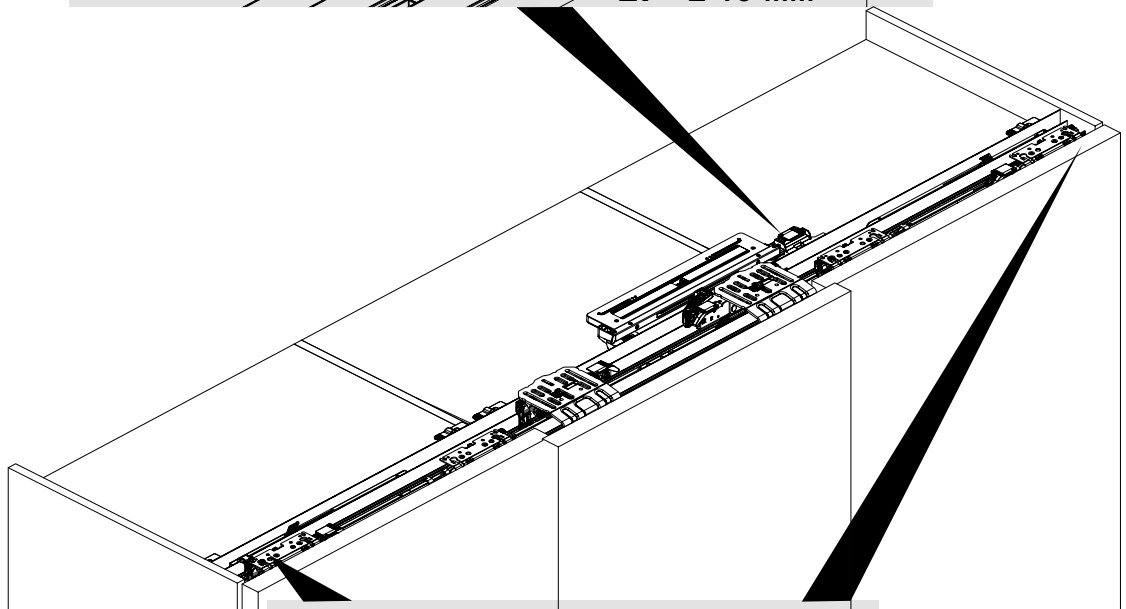
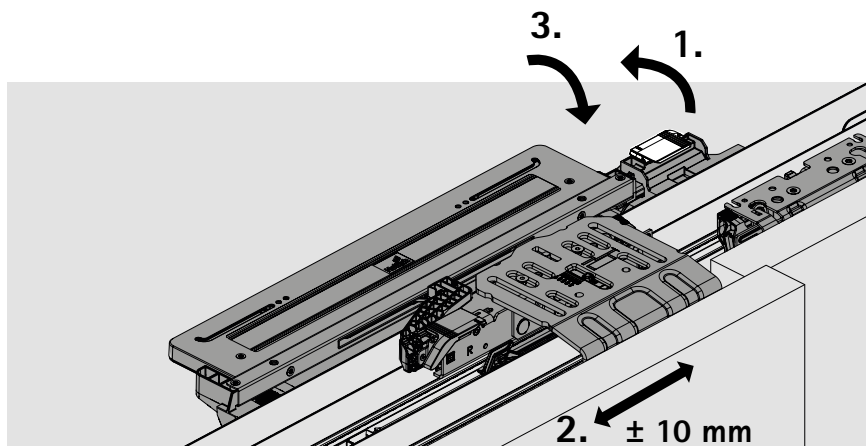
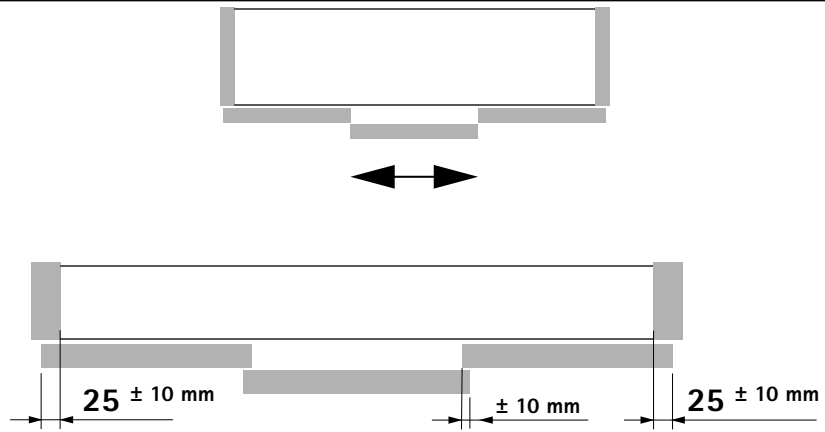

B

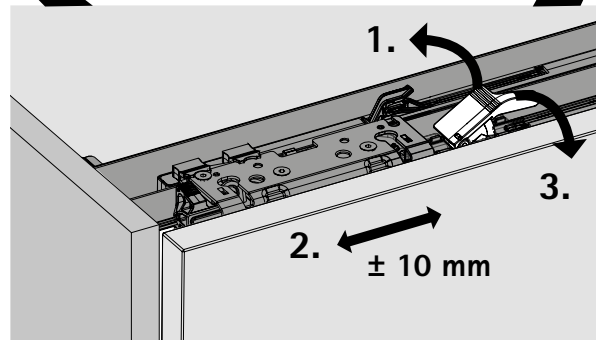
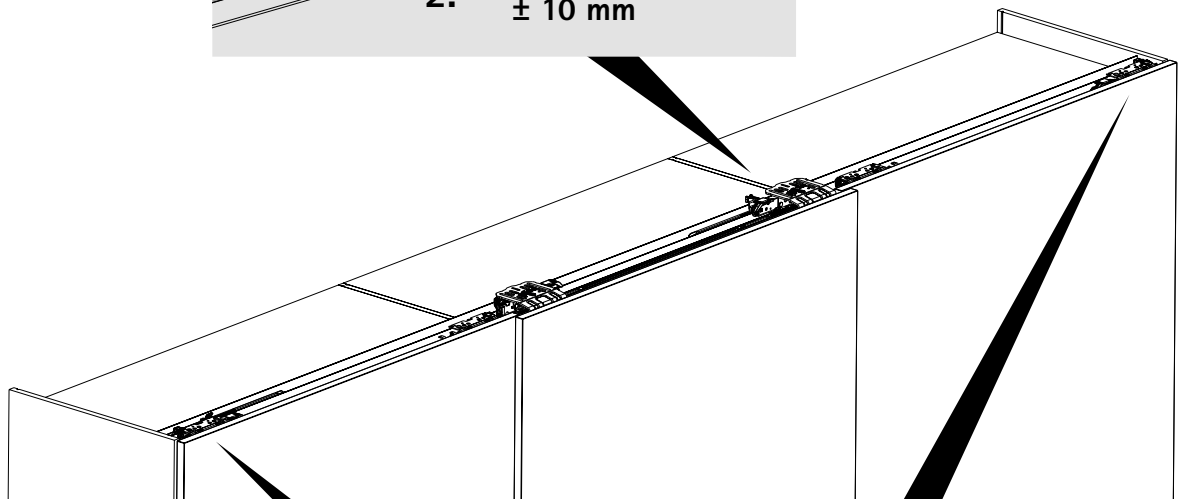
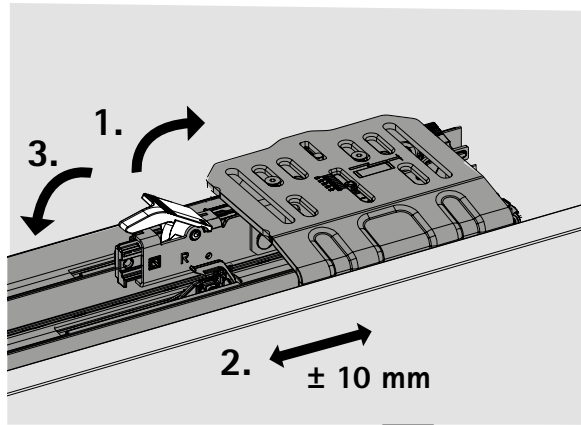
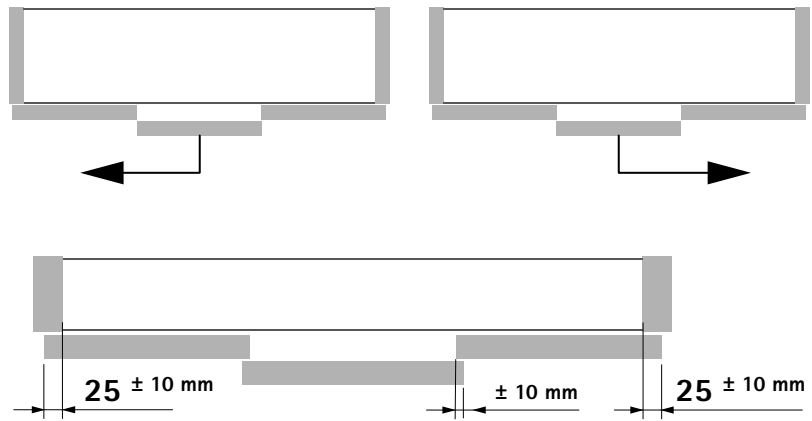

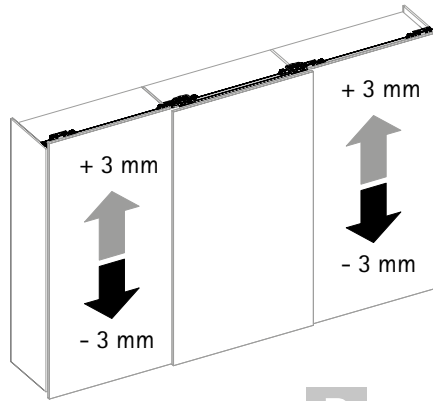
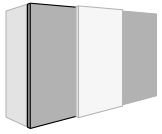

A

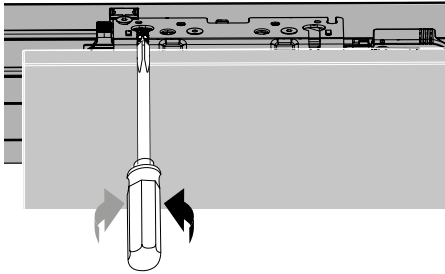

B

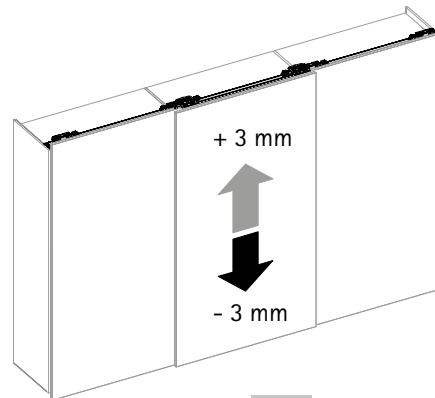
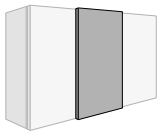
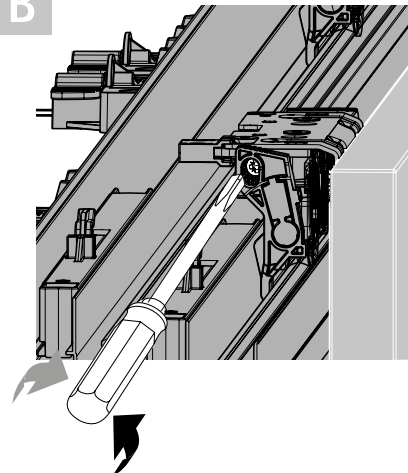

A

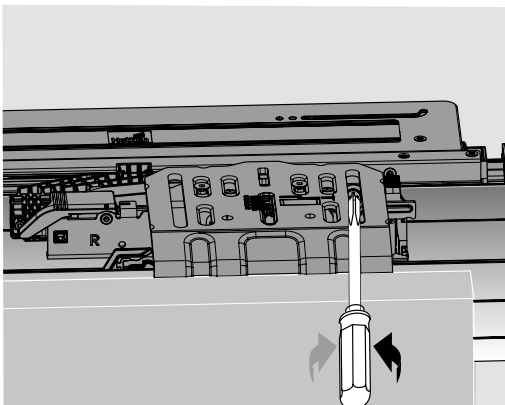

B

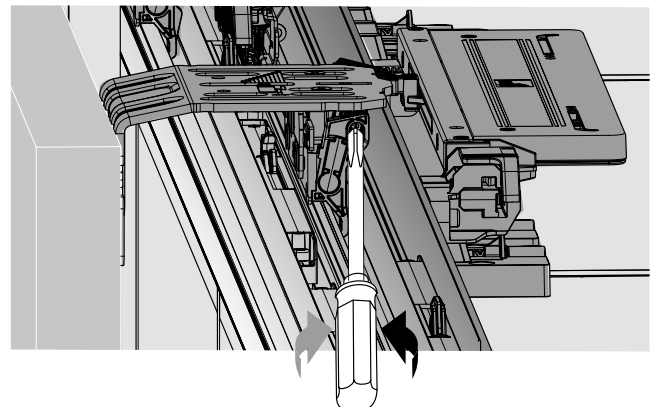

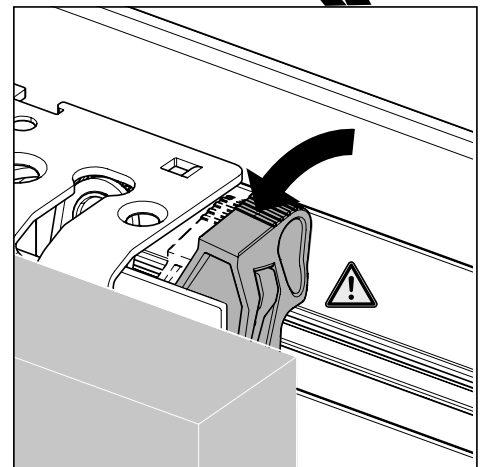
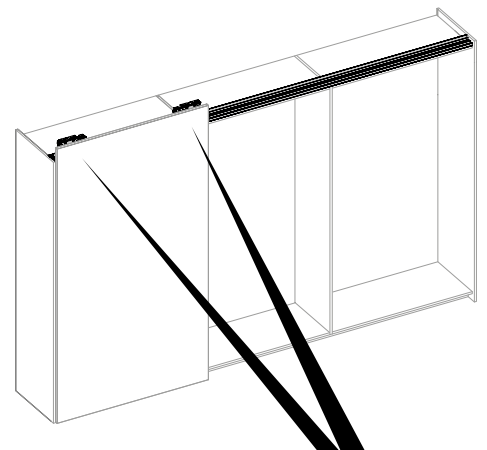
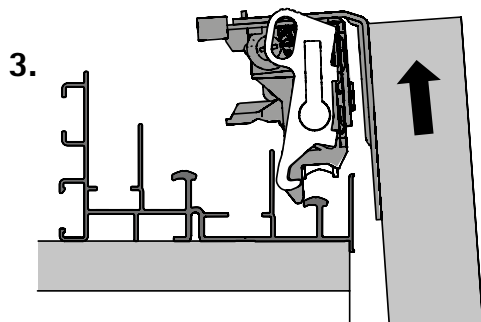
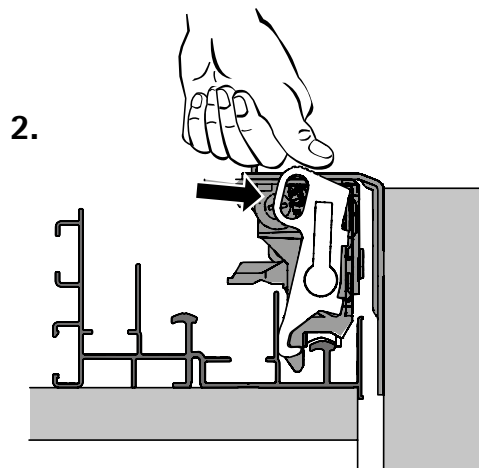
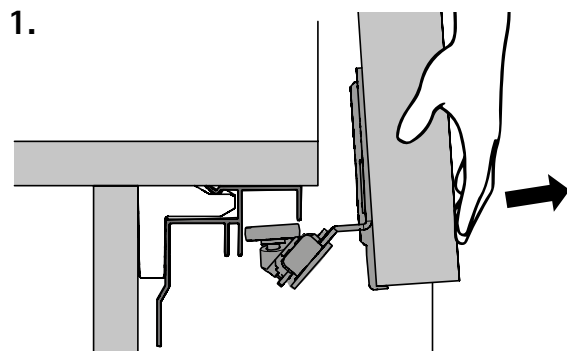
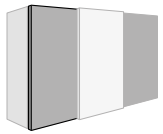

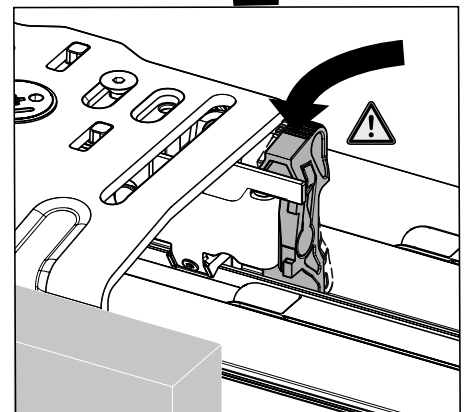
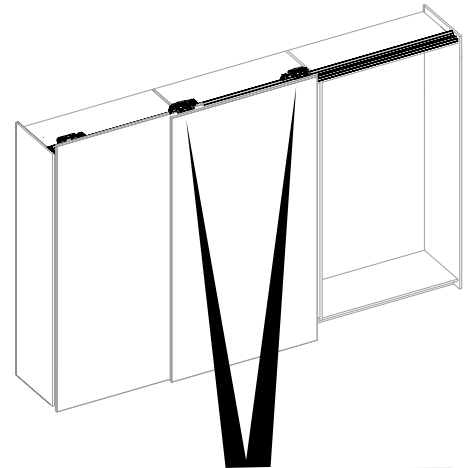
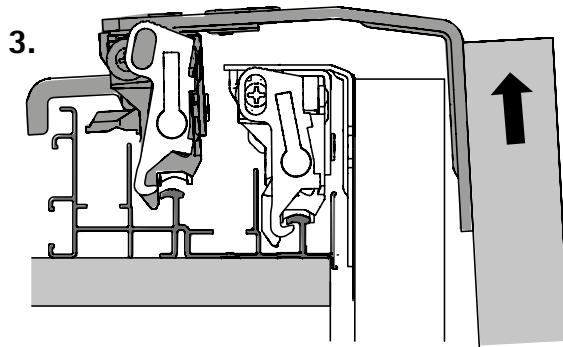
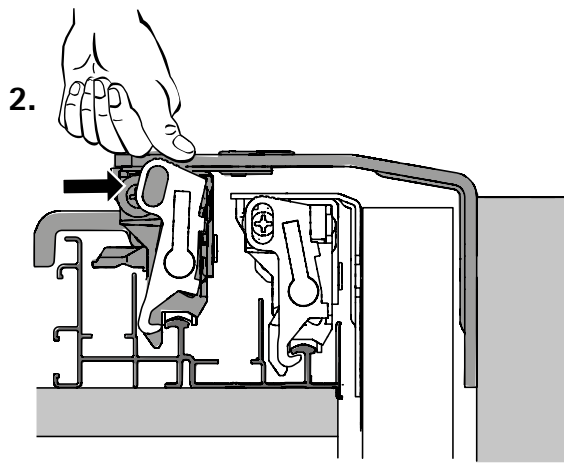
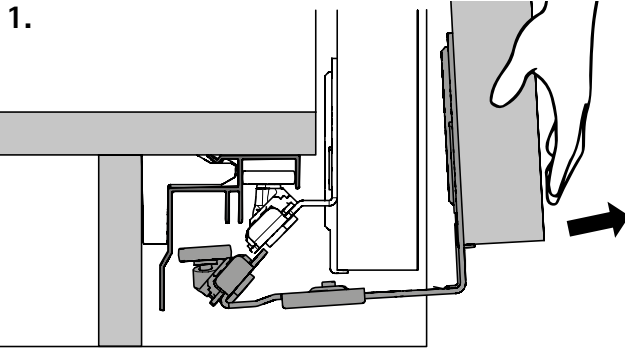
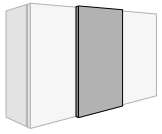



Technik für Möbel

